

CONSTITUENT MATERIALS**1. Define Aggregate.**

Aggregates are defined as inert, granular, and inorganic materials that normally consist of stone or stone-like solids. Aggregates can be used alone (in road bases and various types of fill) or can be used with cementing materials (such as Portland cement or asphalt cement) to form composite materials or concrete.

2. What are the various tests which are to be done on aggregates?

Various test which are done on aggregates are listed below

- Sieve Analysis
- Water Absorption
- Aggregate Impact Value
- Aggregate Abrasion Value
- Aggregate Crushing Value

3. What is grade of cement? List any three grades of cement with their strengths.

Grade of cement represents the specific 28 days compressive strength. The

following three grades are given along with their compressive strengths

33 Grade OPC – 33 MPa

43 Grade OPC – 43 MPa

53 Grade OPC – 53 MPa

4. What is meant by hydration of cement?

Cements used for making concrete have the property of reacting chemically with water in an exothermic process called hydration that results in water treatment products.

5. What is false set in cement? Write reasons for it

False set in cement occurs when the gypsum dehydrates as a result of contacting hot clinker at high temperatures in a grinding mill. This creates plaster to form gypsum and stiffen the concrete.

6. Define Abram's water cement law.

According to Abram's water cement law, the strength of concrete depends on the water cement ratio used.





7. What are the properties of Aggregate?

Moisture conditions

The moisture condition of aggregates refers to the presence of water in the pores and on the surface of aggregates.

Density and specific gravity

Density (D): weight per unit volume (excluding the pores inside a single aggregate)

Solid V weight D = Bulk density: the volume includes the pores inside a single

aggregate.

8. What are the types of cement?

Ordinary Portland cement, rapid hardening cement, low heat cement, blast

furnace slag cement, sulphate resistant cement, air entraining cement, white and

coloured cement, high alumina cement, pozzolanic cement, super sulphate cement,

expansive cement, quick setting cement, water repellent cement, water proofing cement.

9. What is the function of gypsum in the manufacture of cement?

In order to delay the setting action of cement, when mixed with water, a little percentage of gypsum is added in the clinker before grinding them to fine powder.

10. What are bogue's compounds?

- Tricalcium silicate $\text{CaO} \cdot \text{SiO}_2$ C_3S
- Dicalcium silicate $\text{CaO} \cdot \text{SiO}_2$ C_2S
- Tricalcium aluminate $\text{CaO} \cdot \text{Al}_2\text{O}_3$ C_3A
- Tetracalcium aluminoferrite $\text{CaO} \cdot \text{Al}_2\text{O}_3 \cdot \text{Fe}_2\text{O}_3$ C_4AF

11. What are the Chemical Composition of cement?

Oxid e	Per cent content
CaO	60-67
SiO ₂	17-25
Al ₂ O ₃	Alkalies(K ₂ O,Na ₂ O) SO ₃
Fe ₂ O ₃	
MgO	

3.0-8.0

0.5-6.0

0.1-4.0

0.4-1.3

1.3-3.0





12. Mention the test adopted to test the properties of cement in laboratories?

- Fineness
- Consistency test
- Setting time
- Soundness
- Compressive strength

13. Mention the test adopted to test the properties of cement in field?

- Open the bag and take a good look at the cement, there should not be any visible lumps
- Thrust your hand into the cement bag should feel cool feeling
- Take a pinch of cement and feel between the fingers. It should give a smooth feeling not a gritty feeling
- Take a hand full of cement and throw it on a bucket full of water, the particle should float for some time before they sink.

14. What is sulphate attack? What are its effects?

Ordinary Portland cement is susceptible to the attack of sulphates, in particular to the action of magnesium sulphate. Sulphates react both with the free calcium hydroxide in set-cement to form calcium sulphate hydrate and calcium aluminates to form calcium sulpho aluminates, the volume of which is approximately 227% of the volume of the original aluminates. Their expansion within the frame work of hardened cement paste results in cracks and subsequent disruption. Solid sulphates do not attack the cement compound. Sulphates in solution permeate into hardened concrete and attack calcium hydroxide, hydrated calcium aluminates and even hydrated silicates. The above is known as sulphate attack. Sulphate attack is greatly accelerated by alternate wetting and drying which normally takes place in marine structures in the zone of tidal variations.

15. What are the qualities of water?

If water is fit for drinking it is fit for making concrete. This does not appear to be

a true statement for all conditions. Some waters containing a small amount of sugar would be suitable for drinking but not for mixing concrete and conversely water suitable for making concrete may not necessarily be fit for drinking. Some specification also accept water for making concrete if the pH value of water lies between 6 and 8 and the water is free from organic matter.





1. Explain in detail about the various types of cement.

1. Ordinary Portland Cement
 - (i) Ordinary Portland Cement 33
 - (ii) Grade Ordinary Portland Cement 43
 - (iii) Grade Ordinary Portland Cement 53
2. Rapid Hardening Cement
3. Extra Rapid Hardening Cement
4. [Sulphate Resisting Cement Portland](#)
5. [Slag Cement Quick Setting Cement](#)
6. [Super Sulphated Cement Low Heat](#)
7. [Cement](#)
8. [Portland Pozzolana Cement Air Entr](#)
9. [aining Cement](#)
10. [Coloured Cement: White Cement H](#)
11. [ydrophobic Cement](#)
12. [Masonry Cement Expansive Cemen](#)
13. [t](#)
High Alumina Cement
- 14.

15.

Ordinary Portland Cement

The OPC was classified into three grades, namely 33 grade, 43 grade and 53 grade depending upon the strength of the cement at 28 days when tested as per IS 4031-1988.

- If the day strength is less than 33N/mm², it is called 33 grade cement, the strength is not less than 43N/mm², it is called 43 grade cement, and if the strength is not less than 53 N/mm², it

strength obtained are much higher than the BIS specifications.

- To upgrade the qualities of cement by using high quality limestone modern equipment closer to the line of control of maintaining better particle size distribution, finer grinding and better packing. Generally use of high grade cement offers many advantages for making stronger concrete. Although they are



little costlier than low grade cement, they offer 10-20% savings in cement consumption and also they offer many other hidden benefits. One of the most important benefits is the faster rate of development of strength.

Rapid Hardening Cement

• This cement is similar to ordinary Portland cement. Rapid hardening cement which develops higher rate of development of strength should not be

confused with quick-setting cement which only sets quickly. Rapid hardening cement

develops at the age of three days, the same strength as that is expected of ordinary

Portland cement at seven days.

- The rapid rate of development of strength is attributed to the higher fineness of grinding (specific surface not less than 3250 sq. cm per gram) and higher C_3S and lower C_2S content.

- A higher fineness of cement particles expose greater surface area for action of water and also higher proportion of C_3S results in quicker hydration.

Consequently,

Rapid hardening cement gives out much greater heat of hydration during the early period. Therefore, rapid hardening cement should not be used in mass concrete

construction.

n.

Uses :

(a) In pre-fabricated concrete construction.

(b) Where formwork is required to be removed early for re-use elsewhere,

(c) Road repair works,

(d) In cold weather concrete where the rapid rate of development of strength

reduces the vulnerability of concrete to the frost damage.

Sulphate Resisting Cement

- Ordinary Portland cement is susceptible to the attack of sulphates, in

particular to the action of magnesium sulphate. Sulphates react both with the free

calcium hydroxide in set-cement to form calcium sulphate and with hydrate of

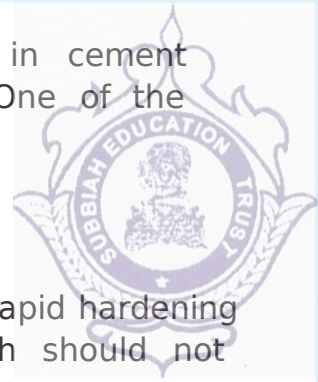

calcium aluminate to form calcium sulpho aluminate, the volume of which is approximately 227% of the volume of the original aluminates. Their expansion within the frame work of hardened cement paste results in cracks and subsequent disruption.

- Solid sulphate do not attack the cement compound. Sulphates in solution permeate into hardened concrete and attack calcium hydroxide, hydrated calcium aluminate and even hydrated silicates. The above is known as sulphate attack. Sulphate attack is greatly aggravated if accompanied by alternate wetting and drying which normally takes place in marine structures in the zone of tidal variations.

- To remedy the sulphate attack, the use of cement with low C_3A content is found to be effective. Such cement with low C_3A and comparatively low C_4AF

content is known as Sulphate Resisting Cement. In other words, this cement has a high silicate content.

The specification generally limits the C_3A content to 5 per cent

Uses :

- (a) Concrete to be used in marine condition;
- (b) Concrete to be used in foundation and basement, where soil is infested with sulphates;
- (c) Concrete used for fabrication of pipes which are likely to be buried in marshy region or sulphate bearing soils;
- (d) Concrete to be used in the construction of sewage treatment works.

Portland Slag Cement

- Portland slag cement is obtained by mixing Portland cement clinker, gypsum and granulated blast furnace slag in suitable proportions and grinding the mixture to get a thorough and mixture between the constituents.

- It may also be manufactured by separately grinding Portland cement clinker, gypsum and ground granulated blast furnace slag and later mixing them intimately.

- The resultant product is a cement which has physical properties similar to those of ordinary Portland cement. In addition, it has low heat of hydration and is relatively better resistant to chlorides, soils and water containing excessive amount of

sulphates or alkali metals, alumina and iron, as well as, to acidic waters, and therefore, this can be used for marine works with advantage.

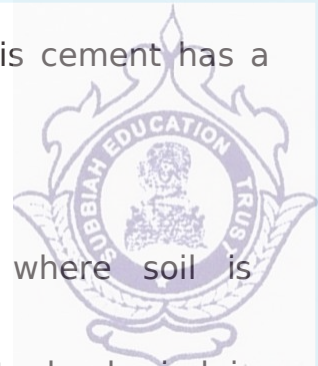
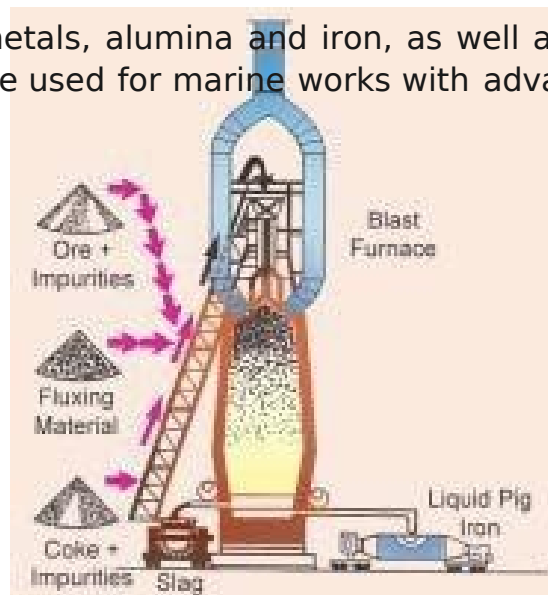

- The manufacture of blast furnace slag cement has been developed primarily to utilize blast furnace slag, a waste product from blast furnaces. The development



of this type of cement has considerably increased the total output of cement production in India .

- The quantity of granulated slag mixed with portland clinker will range from 25-

65 percent. Early strength is mainly due to the cement clinker fraction and later

strength is that due to the slag fraction. Separate grinding is used as an easy means of

varying the slag clinker proportion in the finished cement Portland blast furnace

cement is similar to ordinary Portland cement with respect to fineness, setting time,

soundness and strength.

- It is generally recognised that the rate of hardening of Portland blast furnace

slag cement in mortar or concrete is somewhat slower than that of ordinary Portland

cement during the first 28 days, but thereafter increases, so that at 12 months the

strength becomes close to or even exceeds those of Portland cement.

- The heat of hydration of Portland blast furnace cement is lower than that of

ordinary Portland cement. So this cement can be used in mass concrete structures

with advantage. However, in cold weather the low heat of hydration of Portland blast

furnace cement coupled with moderately low rate of strength development, can lead to frost damage.

- Extensive research shows that the presence of GGBS leads to the enhancement of the intrinsic properties of the concrete both in fresh and hardened states.

Advantages:

- (a) Reduced heat of hydration
- (b) Refinement of pore structure
- (c) Increased resistance to chemical attack.

- The slag which is used in the manufacture of various slag cement is chilled very rapidly either by pouring it into a large body of water or by subjecting the slag stream to jets of water, or of air and water.

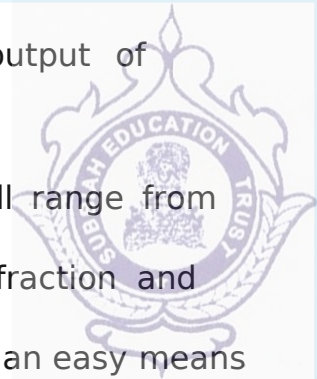

- The purpose is to cool the slag quickly so that crystallisation is prevented and it solidifies as glass. The product is called granulated slag. Portland slag cement exhibits very low diffusivity to chloride ions and such slag cement gives better resistance to corrosion of steel reinforcement.

Application of GGBS Concrete

In recent years the use of GGBS concrete is also recommended for use in water retaining structures. Aggressive water can affect concrete foundations. In such conditions GGBS concrete can perform better.



Quick Setting Cement

- This cement as the name indicates sets very early. The early setting property is brought out by reducing the gypsum content at the time of clinker grinding.
- This cement is required to be mixed, placed and compacted very early. It is used

mostly in under water construction where pumping is involved. Use of quick setting

cement in such conditions reduces the pumping time and makes it economical.

Quick setting cement may also find its use in some typical grouting operations.

Low Heat Cement

It is well known that hydration of cement is an exothermic action which

produces large quantity of heat during hydration. Formation of cracks in large body

of concrete due to heat of hydration has focussed the attention of the concrete

technologists to produce a kind of cement which produces less heat or the same

amount of heat, at a low rate during the hydration process.

- Cement having this property was developed in U.S.A. during 1930 for use in mass concrete construction, such as dams, where temperature rise by the heat of hydration can become excessively large.
- A low-heat evolution is achieved by reducing the contents of C_3S and C_3A which are the compounds evolving the maximum heat of hydration and increasing C_2S .
- A reduction of temperature will retard the chemical action of hardening and so further restrict the rate of evolution of heat. The rate of evolution of heat will, therefore, be less and evolution of heat will extend over a longer period.

Therefore, the feature of low-heat cement is a slow rate of gain of strength. But the

ultimate strength of low-heat cement is the same as that of ordinary Portland cement.

As per the Indian Standard Specification the heat of hydration of low-heat Portland



cement shall be as follows:

7 days — not more than 65 calories per gm.

28 days — not more than 75 calories per gm.

- The specific surface of low heat cement as found out by air-permeability method is not less than 3200 sq. cm/gm. The 7 days strength of low heat cement is not less than 16 MPa in contrast to 22 MPa in the case of ordinary Portland cement. Other properties, such as setting time and soundness are same as that of ordinary Portland cement.

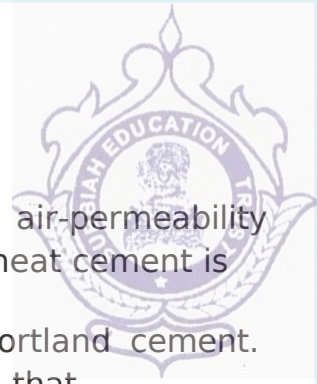

2. Explain in detail the tests for cement.

Testing of cement can be brought under two categories:

- (a) Field testing
- (b) Laboratory testing.

Field Testing

It is sufficient to subject the cement to field tests when it is used for minor works. The following are the field tests:

- (a) Open the bag and take a good look at the cement. There should not be any visible lumps. The colour of the cement should normally be greenish grey.
- (b) Thrust your hand into the cement bag. It must give you a cool feeling. There should not be lump inside.
- (c) Take a pinch of cement and feel-between the fingers. It should give a smooth and not a gritty feel
- (d) Take a handful of cement and throw it on a bucket full of water, the particles should float for some time before they sink.
- (e) Take about 100 grams of cement and a small quantity of water and make a stiff paste. From the stiff paste, pat a cake with sharp edges. Put it on a glass plate and slowly take it under water in a bucket. See that the shape of the cake is not disturbed while taking it down to the bottom of the bucket. After 24 hours the cake should retain its original shape and at the same time it should also set and attain some strength.

Laboratory testing :

The following tests are usually conducted in the laboratory.

- (a) Fineness test.
- (b) Setting time test.
- (c) Strength test.
- (d) Soundness test.
- (e) Heat of hydration test.
- (f) Chemical composition test.

Fineness Test

The fineness of cement has an important bearing on the rate of hydration and hence on the rate of gain of strength and also on the rate of evolution of heat. Finer



offers a greater surface area for hydration and hence faster the development of strength,

Fineness of cement is tested in two ways :

- By sieving.
- By determination of specific surface (total surface area of all the particles in one gram of cement) by air-permeability apparatus. Expressed as cm^2/gm or

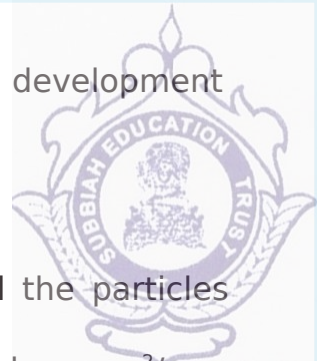

Sieve Test

- Weigh correctly 100 grams of cement and take it on a standard IS Sieve No. 9 (90 microns). Breakdown the air-set lumps in the sample with fingers.

Continuously sieve the sample giving circular and vertical motion for a period of 15 minutes.

- Mechanical sieving devices may also be used. Weigh the residue left on the sieve. This weight shall not exceed 10% for ordinary cement. Sieve test is rarely used.

1. Air Permeability Method

This method of test covers the procedure for determining the fineness of

cement as represented by specific surface expressed as total surface area in sq. cm/gm. of cement. It is also expressed in m²/kg. Lea and Nurse Air Permeability Apparatus is shown in Fig. 2.6. This apparatus can be used for measuring the specific surface of cement.

- The principle is based on the relation between the flow of air through the cement bed and the surface area of the particles comprising the cement bed. From

this the surface area per unit weight of the body material can be related to the permeability of a bed of a given porosity.

- The cement bed in the permeability cell is 1 cm. high and 2.5 cm. in diameter.

Knowing the density of cement the weight required to make a cement bed of porosity of 0.475 can be calculated.

- Slowly pass on air through the cement bed at a constant velocity. Adjust the rate of air flow until the flowmeter shows a difference in level of 30-50 cm. Read the difference in level (h_1) of the manometer and the difference in level (h_2) of the flowmeter.

- Repeat these observations to ensure that steady conditions have been obtained

as shown by a constant value of h_1/h_2 . Specific surface. Fineness can also be measured

by Blaine Air Permeability apparatus. This method is more commonly employed in





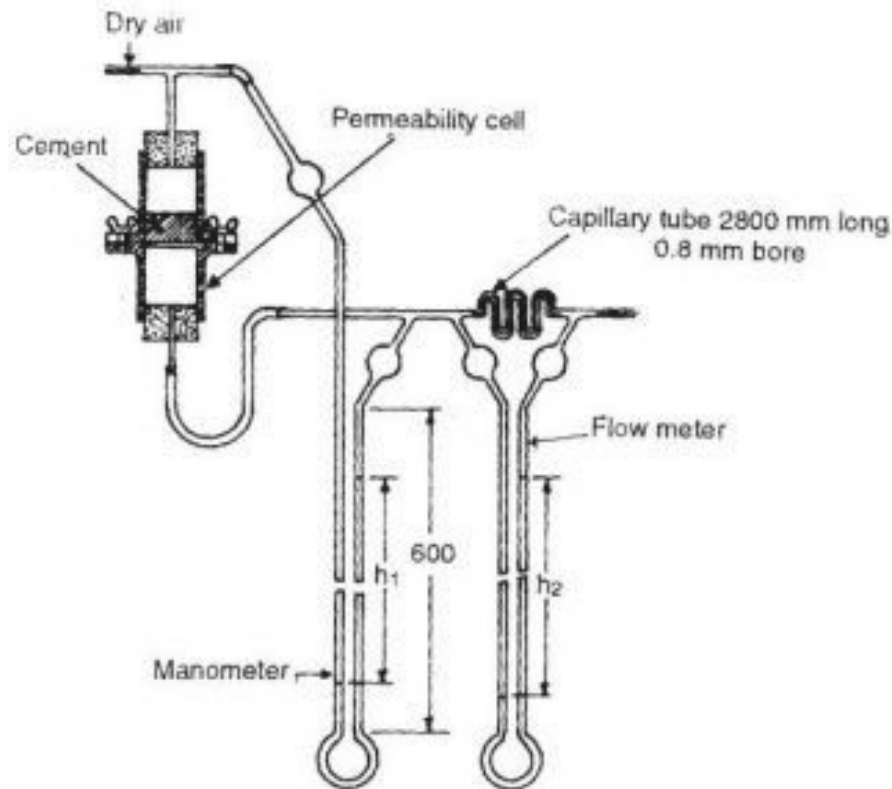

Permeability Apparatus

Standard Consistency Test

- For finding out initial setting time, final setting time and soundness of cement, and strength a parameter known as standard consistency has to be used.

- The standard consistency of cement paste is defined as consistency which will permit a plunger having 10 mm diameter and 50 mm length to penetrate to a depth of 33-35 mm from the top of the mould. The apparatus is called

Vicat Apparatus.

This apparatus is used to find out the percentage of water required to produce a cement paste of standard consistency or normal consistency.

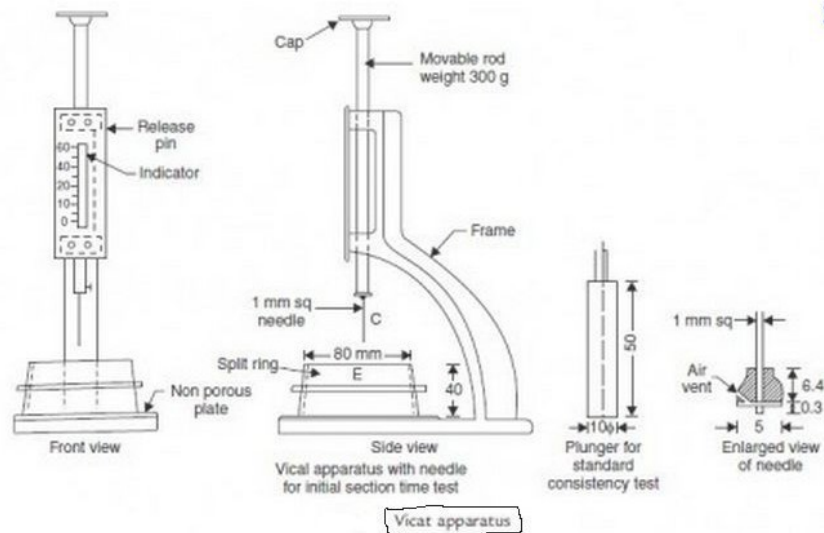

Procedure :

- Take about 50 gms of cement and prepare a test bed with a quantity of water (say 24 per cent by weight of cement) for the first trial.
- The paste must be filled into the Vicat mould within 3-5 minutes. After completely filling the mould, shake the mould to expel air. A standard plunger, 10 mm diameter, 50 mm long is brought down to touch the surface of the paste. The test block is quickly released allowing it to sink into the paste by its own weight.
- Take the reading by noting the penetration of the plunger. Conduct a 2nd trial (say with 25 per cent of water) and find out the depth of penetration of plunger.
- Similarly, conduct trial with higher and higher water/cement ratio till such time that plunger penetrates for a depth of 33-35 mm from the top. That particular percentage of water which allows the plunger to penetrate only to a depth of 33-35 mm from the top is known as the percentage of water required to

produce cement paste of consistency. This percentage is usually a neat standard. P' .

- The test is required to be conducted in a constant temperature ($27^\circ \pm 2^\circ\text{C}$) and constant humidity (90%).

Setting Time Test

- Initial setting time is the elapsed time between the moment that water is added to the cement, to the time that the paste starts losing its plasticity.
- The final setting time is the time elapsed between the moment that water is added to the cement, and the time when the paste has completely lost its plasticity.



has attained sufficient firmness to resist certain definite pressure.

- In actual construction dealing with cement paste, mortar or concrete certain

time is required for mixing, transporting, placing, compacting and finishing. During

this time cement paste, mortar, or concrete should be in plastic condition. The time

interval for which the cement products remain in plastic condition is known as the

initial setting time. Normally a minimum of 30 minutes is given for mixing and handling

operations.

- . Once the concrete is placed in the final position, compacted and finished, it

should lose its plasticity in the earliest possible time so that it is least vulnerable to

damages from external destructive agencies. This time should not be more than 10

hours which is often referred to as final setting

time. **Preparation of specimen**

- Take 500 gm. of cement sample and gauge it with 0.85 times the water required

to produce cement paste of standard consistency (0.85 P). The paste shall be gauged

and filled into the Vicat mould in specified manner within 3-5 minutes. Start the stop

watch the moment water is added to the cement. The temperature of water at the

time of gauging shall be within $27^{\circ}\text{C} \pm 2^{\circ}\text{C}$.

Procedure

INITIAL SETTING TIME.

Lower the needle (C) gently and bring it in contact with the surface of the test

block and quickly release. Allow it to penetrate into the test block and the needle

will completely pierce through the test block. But after some time when the

paste starts losing its plasticity, the needle may penetrate only to a depth of



33-35 mm from the top. The period elapsing between the time when water is added to the cement and the time at which the needle penetrates the test block to a depth equal to 33-35 mm from the top is taken as initial setting time.

FINAL SETTING TIME

Replace the needle (C) of the Vicat apparatus by a circular attachment (F). The cement shall be considered as finally set when, upon, lowering the attachment gently over the surface of the test block, the centre needle makes an impression, while the circular cutting edge of the attachment fails to do so. In other words the paste has attained the hardness and the centre needle does not pierce through the paste more than 0.5 mm.

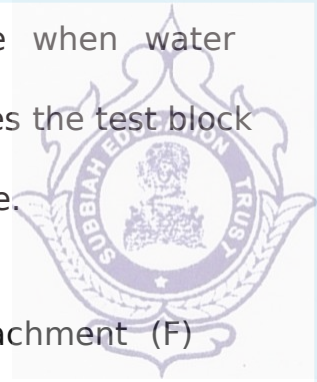

Strength Test

The compressive strength of hardened cement is the most important of all the

properties. The test is made near cement past because of

Strength test is made near cement past because of difficulties excessive shrinkage and subsequent cracking of neat cement.

of Strength of cement is indirectly found on cement sand mortar in specific proportions.

- The standard sand is used for finding the strength of cement. It shall conform to IS

650-1991. Take 555 gms of standard sand (Ennore sand), 185 gms of cement (i.e., ratio

of cement to sand is 1:3) in a non porous enamel tray and mix them with a trowel

for one minute, then add water of quantity + 3.0 per cent of combined weight of

cement and sand and mix the three ingredients thoroughly until the mixture is of uniform colour.

- The time of mixing should not be less than 3 minutes nor more than 4

minutes. Immediately after mixing, the mortar is filled into a cube mould of size 7.06

cm. The area of the face of the cube will be equal to 50 sq cm.

- Compact the mortar either by hand compaction in a standard specified manner on the vibrating equipment (12000RPM) for 2 minutes. Keep the

compacted cube in the mould at a temperature of $27^{\circ}\text{C} \pm 2^{\circ}\text{C}$ and at least 90 per

cent relative humidity for 24 hours. Where the facility of standard temperature and

humidity room is not available, the cube may be kept under wet gunny bag to

simulate 90 per cent relative humidity.

- After 24 hours the cubes are removed from the mould and immersed in clean

fresh water until taken out for testing. The periods being reckoned from the completion of

vibration. The compressive strength shall be the average of the strengths of the



three

cubes for each period respectively.

Soundness Test

- It is very important that the cement after setting shall not undergo any appreciable change of volume. Certain cements have been found to undergo a large expansion after setting causing disruption of the set and hardened mass.

- This will cause serious difficulties for the durability of structures when such cement is used. The testing of soundness of cement, to ensure that the cement does not show any appreciable subsequent expansion is of prime importance.

- The unsoundness in cement is due to the presence of excess of lime than that could be combined with acidic oxide at the kiln. This is also due to inadequate burning or insufficiency in fineness of grinding or thorough mixing of raw materials. It is also likely that too high a proportion of magnesium content or calcium sulphate content may cause unsoundness in cement. For this reason the magnesia content allowed in cement is limited to 6 per cent. It can be recalled that,

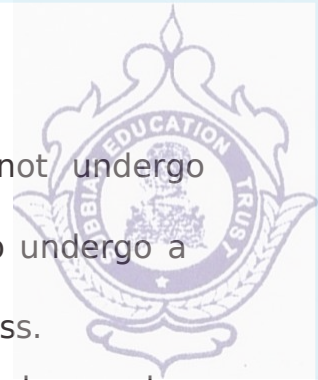

to prevent flash set, calcium sulphate is added to the clinker while grinding.

- The quantity of gypsum added will vary from 3 to 5 per cent depending upon C_3A content. If the addition of gypsum is more than that could be combined with C_3A , excess of gypsum will remain in the cement in free state. This excess of gypsum leads to an expansion and consequent disruption of the set cement paste.

- Unsoundness in cement is due to excess of lime, excess of magnesia or excessive proportion of sulphates. Unsoundness in cement does not come to surface for a considerable period of time. Therefore, accelerated tests are required to detect it.

- There are number of such tests in common use. It consists of a small split cylinder of spring brass or other suitable metal. It is 30 mm in diameter and 30 mm high. On either side of the split are attached two indicator arms 165 mm long with pointed ends.

- Cement is gauged with 0.78 times the water required for standard consistency (0.78 P), in a standard manner and filled into the mould kept on a glass plate. The mould is covered on the top with another glass plate. The whole assembly is immersed in water at a temperature of 27°C - 32°C and kept there for 24 hours.

- Measure the distance between the indicator points. Submerge the mould again in water. Heat the water and bring to boiling point in about 25-30 minutes and keep it boiling for 3 hours. Remove the mould from the water, allow it to cool and measure the distance between the indicator points.

- The difference between these two measurements represents the expansion of cement. This must not exceed 10 mm for ordinary, rapid hardening and low heat Portland cements. If in case the expansion is more than 10 mm as tested above, the cement is said to be unsound. The Le Chatelier test detects unsoundness due to free lime only.

- This method of testing does not indicate the presence and after effect of the excess of magnesia. Indian Standard Specification stipulates that a cement having

a magnesia content of more than 3 per cent shall be tested for soundness by

Autoclave test which is sensitive to both free magnesia and free lime.

- In this test a neat cement specimen 25 × 25 mm is placed in a standard autoclave and the steam pressure inside the autoclave is raised in such a rate as to bring

the gauge pressure of the steam to 21 kg/ sq cm in 1 - 1¹/₄ hour from the time the

heat is turned on. This pressure is maintained for 3 hours.

- The autoclave is cooled and the length measured again. The high steam pressure accelerates the hydration of both magnesia and lime. No satisfactory test

is available for deduction of unsoundness due to an excess of calcium sulphate. But its

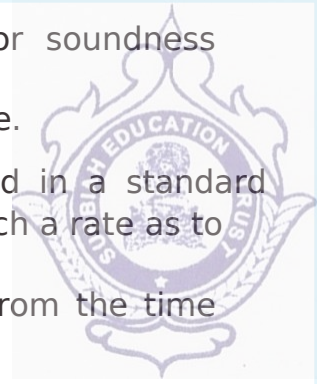

content can be easily determined by chemical analysis.

3. Explain in detail about mechanical properties of aggregate .

The mechanical properties of aggregate can be determined by using following

test

- Test for determination of aggregate crushing value
- Test for determination of 'ten per cent fines value'
- Test for determination of aggregate impact value
- Test for determination of aggregate abrasion value

1. Test For Determination of Aggregate Crushing Value :

- Strength of rock is found out by making a test specimen of cylindrical shape of

size 25 mm diameter and 25 mm height. This cylinder is subjected to compressive

stress. Different rock samples are found to give different compressive strength varying

from a minimum of about 45 MPa to a maximum of 545 MPa.

- As said earlier, the compressive strength of parent rock does not exactly indicate the strength of aggregate in concrete. For this reason assessment of strength of

the aggregate is made by using a sample of bulk aggregate in a standardized manner.

This test is known as aggregate crushing value test. Aggregate crushing value gives a

relative measure of the resistance of an aggregate sample to crushing under gradually applied compressive load. Generally, this test is made on single sized

aggregate passing 12.5 mm and retained on 10 mm sieve.

- The aggregate is placed in a cylindrical mould and a load of 40 ton is applied through a plunger. The material crushed to finer than 2.36 mm is separated and

expressed as a percentage of the original weight taken in the mould. This

percentage is referred as aggregate crushing value. The crushing value of aggregate is restricted to 30 per cent for concrete used for roads and pavements

and 45 per cent may be permitted for other structures.

- The crushing value of aggregate is rather insensitive to the variation in strength of weaker aggregate. This is so because having been crushed before the



application of the full load of 40 tons, the weaker materials become compacted, so that the amount of crushing during later stages of the test is reduced. For this reason a simple test known as —10 per cent fines value□ is introduced. When the aggregate crushing value become 30 or higher, the result is likely to be inaccurate, in which case the aggregate should be subjected to —10 per cent fines value□ test which gives a better picture about the strength of such aggregates.

- This test is also done on a single sized aggregate as mentioned above. Load required to produce 10 per cent fines (particles finer than 2.36 mm) is found out by observing the penetration of plunger. The 10 per cent

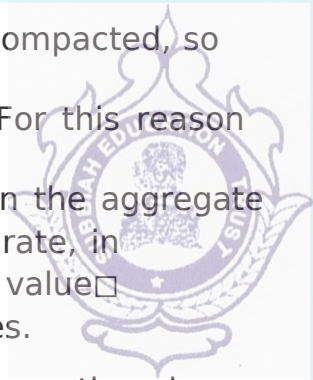

finer value test shows a good correlation with the standard crushing value test for strong aggregates while for weaker aggregates this test is more sensitive and gives a truer picture of the differences between more or less weak samples.

- It should be noted that in the 10 per cent finer value test unlike the crushing

value test, a higher numerical result denotes a higher strength of the aggregate. The

detail of this test is given at the end of this chapter under testing of aggregate.

2) Test for determination of 'ten per cent finer value' :

- The sample of aggregate for this test is the same as that of the sample used for

aggregate crushing value test. The test sample is prepared in the same way as

described earlier. The cylinder of the test apparatus is placed in position on the base

plate and the test sample added in thirds, each third being subjected to 25 strokes by

tamping rod. The surface of the aggregate is carefully levelled and the plunger

inserted so that it rests horizontally on this surface.

- The apparatus, with the test sample and plunger in position is placed in the compression testing machine. The load is applied at a uniform rate so as to cause a

total penetration of the plunger in 10 minutes of about: 15.00 mm for rounded

or partially rounded aggregates (for example uncrushed gravels) 20.0 mm for normal

crushed aggregates, and 24.0 mm for honeycombed aggregates (for example, expanded shales and slags).

- After reaching the required maximum penetration, the load is released and the

whole of the material removed from the cylinder and sieved on a 2.36 mm I.S. Sieve.

$$\frac{14 \times X}{Y + 4}$$

The fines passing the sieve is weighed and the weight is expressed as a percentage of the weight of the test sample. This percentage would fall within the range 7.5 to 12.6,

but if it does not, a further test shall be made at a load adjusted as

appropriate to bring the percentage fines with the range of 7.5 to 12.5 per cent.

Repeat test is made and the load is found out which gives a percentage of fines within the range of 7.5 to 12.5.

Load required for 10 per cent fines =

where, X = load in tons, causing 7.5 to 12.5 percent

fines. Y = mean percentage fines from two tests at

X tons load.

3. Test for determination of Aggregate Impact Value

- With respect to concrete aggregates, toughness is usually considered the resistance of the material to failure by impact. Several attempts to develop a method of test for aggregates impact value have been made. The most successful is the one in which a sample of standard aggregate kept in a mould is subjected to fifteen blows of a metal hammer of weight 14 Kgs. falling from a height of 38 cms.

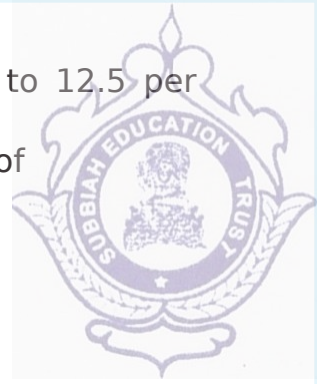

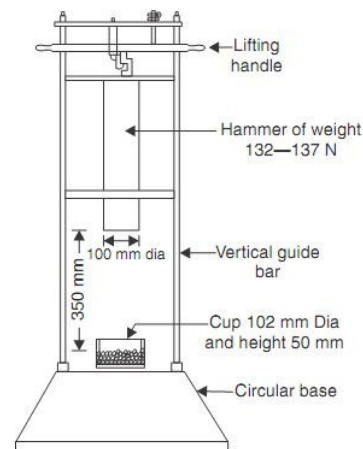

- The quantity of finer material (passing through 2.36 mm) resulting from pounding will indicate the toughness of the sample of aggregate. The ratio of the weight of the fines (finer than 2.36 mm size) formed, to the weight of the total sample taken is expressed as a percentage. This is known as aggregate impact value IS 283-1970 specifies that aggregate impact value shall not exceed 45 per cent by weight for aggregate used for concrete other than wearing surface and 30 per cent by weight, for concrete for wearing surfaces, such as run ways, roads and pavements.

4. Test for determination of Aggregate Abrasion Value

Apart from testing aggregate with respect to its crushing value, impact resistance, testing the aggregate with respect to its resistance to wear is an important test for aggregate to be used for road constructions, ware house floors and pavement construction. Three tests are in common use to test aggregate abrasion for its resistance.

- (i) Deval attrition test (ii) Dorry abrasion test (iii) Los Angeles test.

Deval Attrition Test

In the Deval attrition test, particles of known weight are subjected to wear in an iron cylinder rotated 10000 times at certain speed. The proportion of

material crushed finer than 1.75 mm size is expressed as a percentage of the original

material taken. This percentage is taken as the attrition value of the aggregate.

This test has been covered by IS 2386 (Part IV) – 1963. But it is pointed out that wherever possible Los Angeles test should be used.



Dorry Abrasion Test

This test is not covered by Indian Standard Specification. The test involves in subjecting a cylindrical specimen of 25 cm height and 25 cm diameter to the abrasion against rotating metal disk sprinkled with quartz sand. The loss in weight of the cylinder after 1000 revolutions of the table is determined

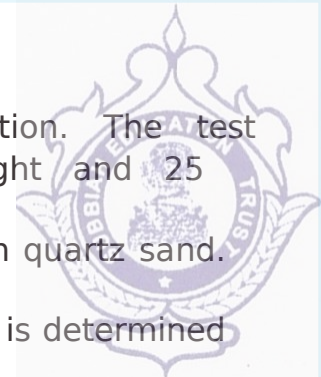
**4. Explain in detail about the test carried in aggregate.**

The various test carried out in aggregate are

- Sieve analysis test
- Test for determination of flakiness index
- Test for determination of elongation index
- Test for determination of clay, fine silt and fine dust
- Test for determination of organic impurities

1) Sieve Analysis Test :

The sieve analysis is conducted to determine the particle size distribution in a sample of aggregate, which we call gradation. A convenient system of expressing the gradation of aggregate is one which the consecutive sieve openings are constantly doubled, such as 10 mm, 20 mm, 40 mm etc. Under such a system, employing a logarithmic scale, lines can be spaced at equal intervals to represent the successive sizes.

- The aggregates used for making concrete are normally of the maximum size 80 mm, 40 mm, 20 mm, 10 mm, 4.75 mm, 2.36 mm, 600 micron, 300 micron and 150 micron. The aggregate fraction from 80 mm to 4.75 mm are termed as coarse aggregate and those fraction from 4.75 mm to 150 micron are termed as fine aggregate. The size 4.75 mm is a common fraction appearing both in coarse aggregate and fine aggregate (C.A. and F.A.).

- Grading pattern of a sample of C.A. or F.A. is assessed by sieving a sample successively through all the sieves mounted one over the other in order of size, with

larger sieve on the top. The material retained on each sieve after shaking, represents the fraction of aggregate coarser than the sieve in question and finer than the sieve above.

- Sieving can be done either manually or mechanically. In the manual operation

the sieve is shaken giving movements in all possible direction to give chance to all

particles for passing through the sieve. Operation should be continued till such time

that almost no particle is passing through. Mechanical devices are actually designed

to give motion in all possible direction, and as such, it is more systematic and efficient

than hand sieving.



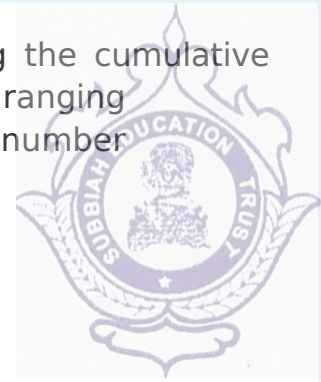

- Fineness modulus is an empirical factor obtained by adding the cumulative percentages of aggregate retained on each of the standard sieves ranging from 80 mm to 150 micron and dividing this sum by an arbitrary number 100. The larger the figure, the coarser is the material.

The following limits may be taken as guidance:

Fine sand	:	Fineness Modulus	:	2.2	
- 2.6	Medium sand	:	F.M.	:	2.6 - 2.9
Coarse	:		:	2.9 - 3.2	
sand		F.M.			

A sand having a fineness modulus more than 3.2 will be unsuitable for making satisfactory concrete.

2) Test for Determination of Flakiness Index :

- The flakiness index of aggregate is the percentage by weight of particles in it

whose least dimension (thickness) is less than three-fifths of their mean dimension.

The test is not applicable to sizes smaller than 6.3 mm.

- This test is conducted by using a metal thickness gauge, of the description shown in

Fig. A sufficient quantity of aggregate is taken such that a minimum number of 200

pieces of any fraction can be tested. Each fraction is gauged in turn for thickness on

the metal gauge. The total amount passing in the gauge is weighed to an accuracy of

0.1 per cent of the weight of the samples taken. The flakiness index is taken as the total

weight of the material passing the various thickness gauges expressed as a

percentage of the total weight of the sample taken. Table shows the standard

dimensions of thickness and length gauges.

Size of Aggregate	Thickness	Length of Gauge	Flakiness Index
IS Sieve	IS Sieve	mm	%
53 mm	50 mm	33.90	—
50 mm	40 mm	27.00	81.0
40 mm	25 mm	19.00	56.0
37.5 mm	25 mm	16.95	—
30 mm	20 mm	15.50	40.5
20 mm	16 mm	10.80	32.4
16 mm	12.5 mm	8.55	25.6
12.5 mm	10.0 mm	6.75	20.2
10.0 mm	6.3 mm	4.89	14.7

* This dimension is equal to 0.6 times the mean Sieve size.

† This dimension is equal to 1.8 times the mean Sieve size.

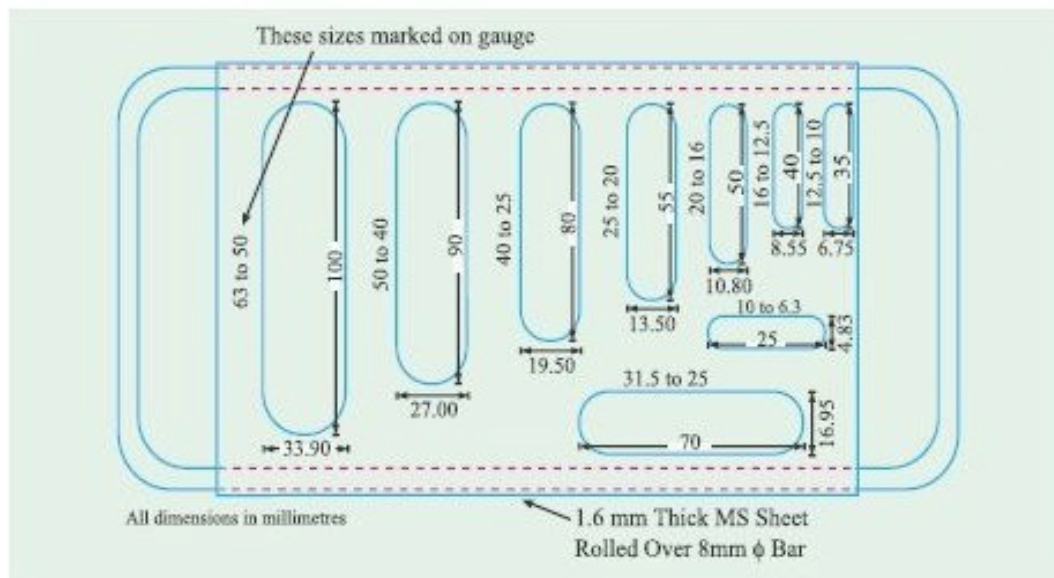

Dimensions of Thickness and Length Gauges (IS: 2386 (Part I) – 1963

3) Test for Determination of Elongation Index :

The elongation index is an aggregate test performed on aggregate particles whose greatest dimension is greater than 1.18 mm. The elongation index is not applicable to sizes smaller than 6.3 mm.

This test is conducted by using length gauges of the type shown in Fig. A. A sufficient quantity of aggregate is taken to provide a minimum number of 200 pieces of any fraction to be tested.

Each fraction shall be gauged individually on the appropriate gauge.

The gauge length used shall be that specified in column of 4 of Table

appropriate size of material. The total amount retained by the gauge length shall be weighed to an accuracy of at least 0.1 per cent of the weight of the test samples taken.

The elongation index is the total weight of the material retained on the

various length gauges expressed as a percentage of the total weight of the sample gauged. The presence of elongated particles in excess of 10 to 15 per cent is generally considered undesirable, but no recognized limits are laid down.



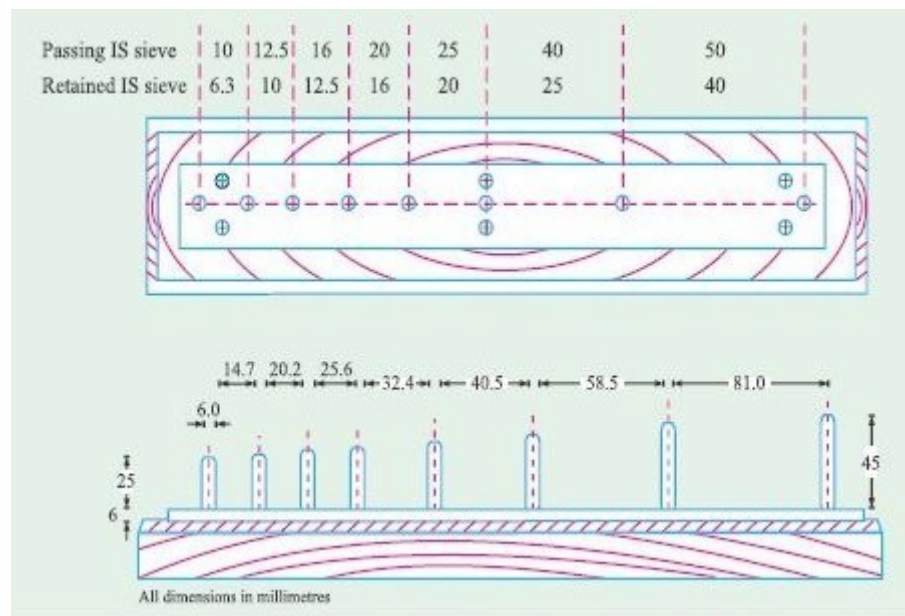

4) Test for Determination of clay, fine silt and fine dust :

This is a gravimetric method for determining the clay, fine silt and fine dust which includes particles upto 20 microns. The sample for test is prepared from the main sample, taking particular care that the test sample contains a correct proportion of the finer material. The amount of sample taken for the test is in accordance with Table

Weight of Sample for Determination of Clay, Fine Silt and Fine Dust

<i>Maximum size present in substantial proportions mm</i>	<i>Approximate weight of sample for Test kg</i>
63 to 25	6
20 to 12.5	1
10 to 6.3	0.5
4.75 or smaller	0.3

- Sedimentation pipette of the description shown in Fig. 3.11 is used for determination of clay and silt content. In the case of fine aggregate, approximately 300 gm. of samples in the air-dry condition, passing the 4.75 mm IS Sieve, is weighed and placed in the screw topped glass jar, together with 300 ml of diluted sodium oxalate solution. The rubber washer and cap are fixed. Care is taken to ensure water



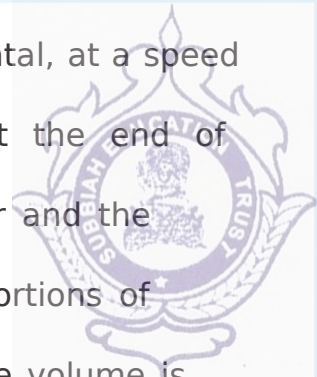

- The jar is then rotated about its long axis with this axis horizontal, at a speed of 80 ± 20 revolutions per minute for a period of 15 minutes. At the end of 15 minutes the suspension is poured into 1000 ml measuring cylinder and the residue washed by gentle swirling and decantation of successive 150 ml portions of sodium oxalate solution, the washings being added to the cylinder until the volume is made upto 1000 ml.

- In the case of coarse aggregate the weighed sample is placed in a suitable container, covered with a measured volume of sodium oxalate solution (0.8 gm per litre), agitated vigorously to remove all fine material adhered and the liquid suspension transferred to the 1000 ml measuring cylinder. This process is repeated till all clay material has been transferred to the cylinder. The volume is made upto 1000 ml with sodium oxalate solution.

- The suspension in the measuring cylinder is thoroughly mixed. The pipette A is then gently lowered until the pipette touches the surface of the liquid, and then lowered a further 10 cm into the liquid. Three minutes after placing the tube in position, the pipette A and the bore of tap B is filled by opening B and applying gentle suction at C. A small surplus may be drawn up into the bulb between tap B and tube C, but this is allowed to run away and any solid matter is washed out with distilled water from E. The pipette is then removed from the measuring cylinder and its contents run into a weighed container. The contents of the container is dried at 100°C to 110°C to constant weight, cooled and weighed.

The percentage of the fine slit and clay or fine dust is calculated from the formula.

where W_1 = weight in gm of the original sample.

W_2 = weight in gm of the dried residue
 V = volume in ml of the pipette and

0.8 = weight in gm of sodium oxalate in one litre of diluted solution



5) Test for Determination of Organic Impurities :

- This test is an approximate method for estimating whether organic compounds are present in the natural sand in an objectionable quantity or within the permissible limit.

- The sand from the natural source is tested as delivered and without drying.
A

350 ml graduated clear glass bottle is filled to the 75 ml mark with 3 per cent solution of sodium hydroxide in water



- The sand is added gradually until the volume measured by the sand layer is 125

ml.

- The volume is then made up to 200 ml by adding more solution. The bottle is then stoppered and shaken vigorously. Roding also may be permitted to dislodge

any organic matter adhering to the natural sand by using glass rod. The liquid is then allowed to stand for 24 hours. The colour of this liquid after 24 hours is compared with a

standard solution freshly prepared, as follows: Add 2.5 ml of 2 per cent solution of

tannic acid in 10 percent alcohol, to 97.5 ml of a 3 per cent sodium hydroxide solution.

- Place in a 350 ml. bottle, stopper, shake vigorously and allow to stand for 24 hours before comparison with the solution above and described in the preceding

paragraph. Alternatively, an instrument or coloured acetate sheets for making the

comparison can be obtained, but it is desirable that these should be verified on receipt by comparison with the standard solution.

6) Test for Determination of Specific Gravity :

Indian Standard Specification IS : 2386 (Part III) of 1963 gives various procedures to find out the specific gravity of different sizes of aggregates. The following procedure is applicable to aggregate size larger than 10 mm.



A sample of aggregate not less than 2 kg is taken. It is thoroughly washed to remove the finer particles and dust adhering to the aggregate. It is then placed in a wire

basket and immersed in distilled water at a temperature between 22° to 32°C.

Immediately after immersion, the entrapped air is removed from the sample by lifting

the basket containing it 25 mm above the base of the tank and allowing it to drop

times at the rate of about one drop per sec. During the operation, care is taken that

the basket and aggregate remain completely

immersed in water. They are kept in water for a period of $24 \pm 1/2$ hours afterwards.

The basket and aggregate are then jolted and weighed (weight A1) in water at a

temperature 22° to 32° C. The basket and the aggregate are then removed from water

and allowed to drain for a few minutes and then the aggregate is taken out from the

basket and placed on dry cloth and the surface is gently dried with the cloth.

The

aggregate is transferred to the second dry cloth and further dried. The

empty basket is again immersed in water, jolted 25 times and weighed in

water

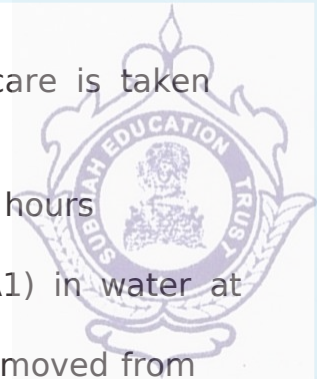

(weight A₂). The aggregate is exposed to atmosphere away from direct sunlight for

not less than 10 minutes until it appears completely surface dry. Then the aggregate is weighed in air (weight B).

$$\text{Specific Gravity} = \frac{C}{B-A}; \quad \text{Apparent Sp. Gravity} = \frac{C}{C-A}$$

$$\text{Water absorption} = \frac{100(B-C)}{C}$$

Then the aggregate is kept in the oven at a temperature of 100 to 110°C and

maintained at this temperature for $24 \pm 1/2$ hours. It is then cooled in the air-tight

container, and weighed (weight C).

$$\text{Bulk density} = \frac{\text{net weight of the aggregate in kg}}{\text{capacity of the container in litre}}; \quad \text{Percentage of voids} = \frac{G_s - \gamma}{G_s} \times 100$$

where, G_s = specific gravity of aggregate and γ = bulk density in kg/litre.

Where, A = the weight in gm of the saturated aggregate in water (A₁ - A₂).

B = the weight in gm of the saturated surface-dry aggregate in air, and

C = the weight in gm of oven-dried aggregate in air.

Test for Determination of Bulk Density and Voids

Bulk density is the weight of material in a given volume. It is normally expressed in kg per litre. A cylindrical measure preferably machined to accurate internal dimensions is used for measuring bulk density. The size of the container for measuring bulk density is shown in Table

Size of Container for Bulk Density Test

<i>Size of Largest Particles</i>	<i>Nominal Capacity</i>	<i>Inside Diameter</i>	<i>Inside Height</i>	<i>Thickness of Metal</i>
	litre	cm	cm	mm
4.75 mm and under	3	15	17	3.15
Over 4.75 mm to 40 mm	15	25	30	4.00
Over 40 mm	30	35	31	5.00

The cylindrical measure is filled about 1/3 each time with thoroughly mixed

aggregate and tamped with 25 strokes by a bullet ended tamping rod, 16 mm diameter

and 60 cm long. The measure is carefully struck off level using tamping rod as a straight



edge. The net weight of the aggregate in the measure is determined and the bulk density is calculated in kg/litre.



5. Describe in detail about the importance of the quality of water used for concreting.

Water is an important ingredient of concrete as it actively participates in the chemical reaction with cement.

Qualities of Water :

A popular yard-stick to the suitability of water for mixing concrete is that, if water is fit for drinking it is fit for making concrete. This does not appear to be a true statement for all conditions. Some waters containing a small amount of sugar would be suitable for drinking but not for mixing concrete and conversely water suitable for making concrete may not necessarily be fit for drinking.

Some specifications require that if the water is not obtained from source that has proved satisfactory, the strength of concrete made with questionable water should be compared with similar concrete or mortar made with pure water. Some specifications also accept water for making concrete if the pH value of water lies between 6 and 8 and the water is free from organic matter.

Instead of depending upon pH value and other chemical composition, the best course to find out whether a particular source of water is suitable for concrete making or not, is to make concrete with this water and compare its 7 days' and 28 days' strength with companion cubes made with distilled water.

If the compressive strength is up to 90 per cent, the source of water may be accepted. This criteria may be safely adopted in places like coastal area of marshy area or in other places where the available water is brackish in nature and of doubtful quality. However, it is logical to know what harm the impurities in water do to the concrete and what degree of impurity is permissible in mixing concrete and curing concrete.



Carbonates and bi-carbonates of sodium and potassium effect the setting time of cement. While sodium carbonate may cause quick setting, the bi-carbonates may either accelerate or retard the setting. The other higher concentrations of these salts will materially reduce the concrete strength. If some of these salts exceeds 1,000 ppm, tests for setting time and 28 days strength should be carried out. In lower concentrations they may be accepted.

Brackish water contains chlorides and sulphates. When chloride does not exceed 10,000 ppm and sulphate does not exceed 3,000 ppm the water is harmless, but water with even higher salt content has been used satisfactorily. Salts of Manganese, Tin, Zinc, Copper and Lead cause a marked reduction in strength of concrete. Sodium iodate, sodium phosphate, and sodium borate reduce the initial strength of concrete to an extra-ordinarily high degree. Another salt that is detrimental

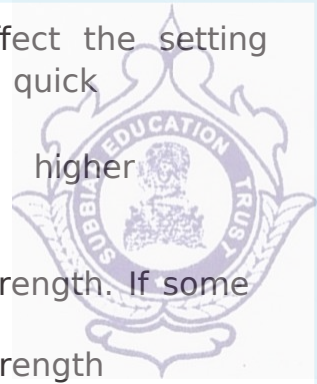

to concrete is sodium sulphide and even a sulphide content of 100 ppm warrants testing.

Silts and suspended particles are undesirable as they interfere with setting, hardening and bond characteristics. A turbidity limit of 2,000 ppm has been suggested. The initial setting time of the test block made with a cement and the water proposed to be used shall not differ by ± 30 minutes from the initial setting time of the test block made with same cement and distilled water.

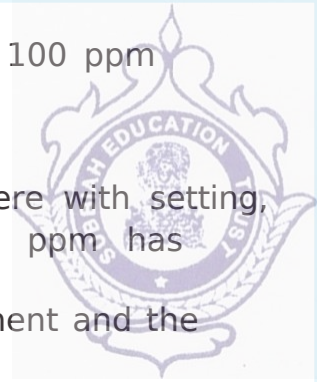

Impurity	Tolerable Concentration
Sodium and potassium carbonates and bi-carbonates	: 1,000 ppm (total). If this is exceeded, it is advisable to make tests both for setting time and 28 days strength
Chlorides	: 10,000 ppm.
Sulphuric anhydride	: 3,000 ppm
Calcium chloride	: 2 per cent by weight of cement in non-pre-stressed concrete
Sodium iodate, sodium sulphate, sodium arsenate, sodium borate	: very low
Sodium sulphide	: Even 100 ppm warrants testing
Sodium hydroxide	: 0.5 per cent by weight of cement, provided quick set is not induced.
Salt and suspended particles	: 2,000 ppm. Mixing water with a high content of suspended solids should be allowed to stand in a settling basin before use.
Total dissolved salts	: 15,000 ppm.
Organic material	: 3,000 ppm. Water containing humic acid or such organic acids may adversely affect the hardening of concrete; 780 ppm. of humic acid are reported to have seriously impaired the strength of concrete. In the case of such waters therefore, further testing is necessary.
pH	: shall not be less than 6

Tolerable Concentrations of Some Impurities in Mixing Water

The following guidelines should also be taken into consideration regarding the quality of water.

- To neutralize 100 ml sample of water using phenolphthalein as an indicator, it should not require more than 5 ml of 0.02 normal NaOH.

- To neutralise 100 ml of sample of water, using mixed indicator, it should not require more than 25 ml of 0.02 normal H_2SO_4



Permissible limit for solids as per IS 456 of 2000



Material	Tested as per	Permissible limit Max.
Organic	IS 3025 (pt 18)	200 mg/l
Inorganic	IS 3025 (pt 18)	3000 mg/l
Sulphates (as SO_3)	IS 3025 (pt 24)	400 mg/l
Chlorides (as Cl)	IS 3025 (pt 32)	2000 mg/l for concrete work not containing embedded steel and 500 mg/l for reinforced concrete work
Suspended	IS 3025 (pt 17)	2000 mg/l

Algae in mixing water may cause a marked reduction in strength of concrete either by combining with cement to reduce the bond or by causing large amount of air entrainment in concrete. Algae which are present on the surface of the aggregate have the same effect as in that of mixing water.

6. Discuss the role of various major components of cement and its hydrated products in the properties of cement

Portland cement gets its strength from chemical reactions between the cement and water. The process is known as hydration. This is a complex process that is best understood by first understanding the chemical composition of cement.

Manufacture of cement

Portland cement is manufactured by crushing, milling and proportioning the following materials:

- Lime or calcium oxide, CaO : from limestone, chalk, shells, shale or calcareous rock
- Silica, SiO_2 : from sand, old bottles, clay or argillaceous rock
- Alumina, Al_2O_3 : from bauxite, recycled aluminum, clay
- Iron, Fe_2O_3 : from from clay, iron ore, scrap iron and fly ash
- Gypsum, $\text{CaSO}_4 \cdot 2\text{H}_2\text{O}$: found together with limestone

The materials, without the gypsum, are proportioned to produce a mixture with the desired chemical composition and then ground and blended by one of two processes - dry process or wet process. The materials are then fed through a kiln at $2,600^\circ\text{F}$ to produce grayish-black pellets known as clinker. The alumina and iron act as fluxing agents which lower the melting point of silica from $3,000$ to 2600°F . After this stage, the clinker is cooled, pulverized and gypsum added to regulate setting time. It is then ground extremely fine



Chemical shorthand

Because of the complex chemical nature of cement, a shorthand form is used to denote the chemical compounds. The shorthand for the basic compounds is:



Compound	Formula
Calcium oxide (lime)	CaO
Silicon dioxide (silica)	SiO ₂
Aluminum oxide (alumina)	Al ₂ O ₃
Iron oxide	Fe ₂ O ₃
Water	H ₂ O
Sulfate	SO ₃

Chemical composition of clinker

The cement clinker formed has the following typical composition:

Compound	Formula
Tricalcium aluminate	Ca ₃ Al ₂ O ₆
Tetracalcium aluminoferrite	Ca ₄ Al ₂ Fe ₂ O ₁₀
Belite or dicalcium silicate	Ca ₂ SiO ₅
Alite or tricalcium silicate	Ca ₃ SiO ₄
Sodium oxide	Na ₂ O
Potassium oxide	K ₂ O
Gypsum	CaSO ₄ .2H ₂ O

Properties of cement compounds

These compounds contribute to the properties of cement in different ways

- Tricalcium aluminate, C₃A:-

It liberates a lot of heat during the early stages of hydration, but has little strength contribution. Gypsum slows down the hydration rate of C₃A. Cement low in C₃A is sulfate resistant.

- Tricalcium silicate, C₃S:-

This compound hydrates and hardens rapidly. It is largely responsible for portland cement's initial set and early strength gain.

- Dicalcium silicate, C₂S:

C₂S hydrates and hardens slowly. It is largely responsible for strength gain after one week.

- Ferrite, C₄AF:

This is a fluxing agent which reduces the melting temperature of the raw materials in the kiln (from 3,000° F to 2,600° F). It hydrates rapidly, but does not contribute much to strength of the cement paste.

By mixing these compounds appropriately, manufacturers can produce different types of cement to suit several construction environments.





7. What are the raw materials for the manufacture of cement? Mention the functions in the properties of cement.

- Lime
- Silica
- Alumina
- Iron
- oxide
- Magnesium oxide

Lime

- Sulphur trioxide
- Alkalies
- Calcium sulphate

Lime in excess makes the cement unsound and causes the cement to expand and disintegrate.

If it is in deficiency, the strength of cement is decreased and cement sets quickly.

- Therefore it should be in right proportion to produce the cement sound and strong.

Silica

- Silica imparts strength to cement.
- In excess provides greater strength to the cement but at the same time prolongs cement setting time.

Alumina

- It imparts quick setting quality to the cement, lowers the clinkering temperature.
- In excess reduces the strength of cement.

Iron oxide

- Provides color, hardness and strength to cement.

Magnesium oxide

- Imparts hardness and color to cement.
- In excess makes the cement unsound.

Sulphur trioxide

- It makes the cement sound.
- In excess it causes the cement unsound.

Alkalies

- In excess will cause efflorescence.

Calcium sulphate

- Control the initial setting time of cement



CHEMICAL AND MINERAL ADMIXTURES

1. Define Retarders.

A Retarder is an admixture that slows down the chemical process of hydration so that concrete remains plastic and workable for a longer time than

concrete without the retarder. Retarders are used to overcome the accelerating effect

of high temperature on setting properties of concrete in hot weather concreting.

Retarders increase the setting time of concrete mix and reduce the water cement

ratio. Up to 10% water reduction is achieved.

2. Define Accelerators.

Accelerators reduce the setting time and produce early removal of forms and speed up hardening. The common accelerators are CaCl_2 , Al_2Cl_3 , NaCl , Na_2SO_4 . Accelerating admixtures are added to concrete to increase the rate of early strength development in concrete to

- Permit earlier removal of formwork;
- reduce the required period of curing;
- advance the time that a structure can be placed in service;
- partially compensate for the retarding effect of low temperature during cold weather concreting;

3. Define Super plasticizers & List out its advantages.

Super plasticizers produce extreme workability and achieve reduction of water content without loss of water cement ratio i.e. workability.

Super plasticizers can produce:

- at the same w/c ratio much more workable concrete than the plain ones,
- for the same workability, it permits the use of lower w/c ratio,
- as a consequence of increased strength with lower w/c ratio, it also permits a reduction of cement content.

4. What is mean by waterproofing admixtures ?

Waterproofing admixtures may be obtained in powder, paste or liquid form and may consist of pore filling or water repellent materials. The chief materials in the pore filling class are silicate of soda, aluminium and zinc sulphates and aluminium and calcium chloride. These are chemically active pore fillers.

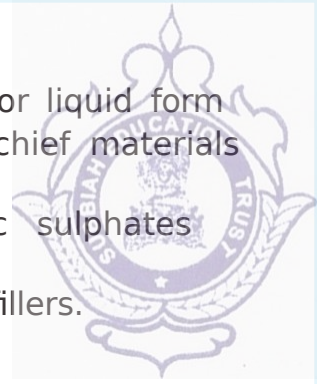

5. Write the classification of fly ash.

Fly ash is classified into two classes.

Class F:

Fly ash normally produced by burning anthracite or bituminous coal, usually has less than 5% CaO. Class F fly ash has pozzolanic properties only.

Class C:

Fly ash normally produced by burning lignite or sub-bituminous coal. Some class C fly ash may have CaO content in excess of 10%. In addition to pozzolanic properties, class C fly ash also possesses cementitious properties.

6. Write the advantages of GGBS in concrete.

The major advantages recognised are

- Reduced heat of hydration
- Refinement of pore structures
- Reduced permeabilities to the external agencies
- Increased resistance to chemical attack.

7. Define chemical admixtures.

Chemicals mixed with concrete ingredients and spread throughout the body of concrete to favorably modify the molding and setting properties of concrete mix known as chemical admixtures.

8. Define Mineral admixtures.

It is a siliceous materials used to strengthen the durability properties that is classified as pozzolanic or cementitious materials. It acts as by-product agent. E.g.: fly ash

9. Define plasticizers and mention its types.

Plasticizers are defined as chemical admixtures added to wet concrete mix to impart adequate workability properties.

- Finely divided minerals
- Air entraining agents
- Synthetic derivatives

10. Mention the few mineral admixtures.

- Fly ash
- Silica fume
- Rice husk ash
- Metakaoline







11. What are the various admixtures used other than chemical and mineral admixtures.

- Gas forming and expansive chemicals
- Pigments
- Antifungal admixtures
- Curing compounds
- Sealants
- Flooring
- Guniting aids.

12. Name the admixtures available in India?

- a. Plasticizers
- Conplast P211- Water reducing plasticizers
 - Conplast P509- Water reducing plasticizers/High performance plasticizers
- b. Super Plasticizers
- Conplast SP337- High workability aid
 - Conplast SP430- High range water reducer

13. What is meant by Pozzolanic action ?

The pozzolanic reaction is the chemical reaction that occurs in portland cement upon the addition of pozzolans. The pozzolanic reaction converts a silica-rich precursor with no cementing properties, to a calcium silicate, with good cementing properties.

14. List Air-entraining admixtures and their properties.

Air-entraining admixtures

Salts of wood resins (Vinsol resin), some synthetic detergents, salts of sulfonated lignin, salts of petroleum acids, salts of proteinaceous material, fatty and resinous acids and their salts, alkylbenzene sulfonates, salts of sulfonated hydrocarbon

Properties of Air-entraining admixtures

Improve durability in freeze-thaw, deicer, sulfate, and alkali- reactive environments
Improve workability



1) Explain in detail about the retarders.

A retarder is an admixture that slows down the chemical process of hydration so that concrete remains plastic and workable for a longer time than concrete without the retarder. Retarders are used to overcome the accelerating effect of high temperature on setting properties of concrete in hot weather concreting.

The retarders are used in casting and consolidating large number of pours without the formation of cold joints. They are also used in grouting oil wells. Oil wells are sometimes taken upto a depth of about 6000 meter deep where the temperature may be about 200°C. The annular spacing between the steel tube and the wall of the well will have to be sealed with cement grout.

Retarding admixtures are sometimes used to obtain exposed aggregate look in concrete. The retarder sprayed to the surface of the formwork, prevents the hardening of matrix at the interface of concrete and formwork, whereas the rest of the concrete gets hardened.

The appropriate amount of gypsum to be used must be determined carefully for the given job. Use of gypsum for the purpose of retarding setting time is only recommended when adequate inspection and control is available, otherwise, addition of excess amount may cause undesirable expansion and indefinite delay in the setting of concrete.

In addition to gypsum there are number of other materials found to be suitable for this purpose. They are: starches, cellulose products, sugars, acids or salts of acids. These chemicals may have variable action on different types of cement when used in different quantities. Unless experience has been had with a retarder, its use as an admixture should not be attempted without

advice. Any mistake made in this respect may have disastrous consequences.

Common sugar is one of the most effective retarding agents used as an admixture for delaying the setting time of concrete without detrimental effect on the ultimate strength. Addition of excessive amounts will cause indefinite delay in setting. At normal temperatures addition of sugar 0.05 to 0.10 per cent have little effect on the rate of hydration, but if the quantity is increased to 0.2 per cent, hydration can be retarded to such an extent that final set may not take place for 72 hours or more.

Skimmed milk powder (casein) has a retarding effect mainly due to sugar content. Other admixtures which have been successfully used as retarding

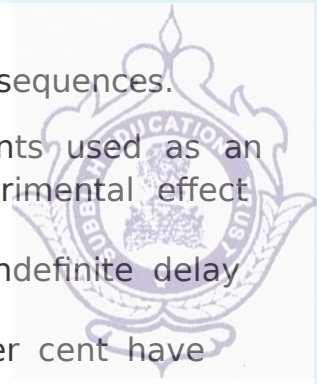

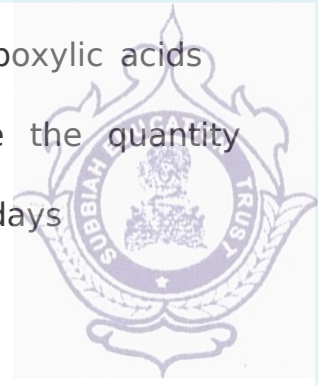

agents are Ligno sulphonic acids and their salts, hydroxylated carboxylic acids and their salts which in addition to the retarding effect also reduce the quantity of water requirement for a given workability. This also increases 28 days compressive strength by 10 to 20 per cent.

Effect of retarding/water-reducing admixtures on setting time and strength build up

Admixture addition litres/50 kgs.	Setting time hrs.		W : C ratio	Compressive Strength MPa		
	Initial	Final		3 days	7 days	28 days
0	4.5	9	0.68	20	28	37
0.14	8.0	13	0.61	28	36	47
0.21	11.5	16	0.58	30	40	50
0.28	16.0	21	0.58	30	42	54

2) Explain in detail about the Accelerators.

Accelerating admixtures are added to concrete to increase the rate of early strength development in concrete to

- Permit earlier removal of formwork;
- reduce the required period of curing;
- advance the time that a structure can be placed in service;
- partially compensate for the retarding effect of low temperature during cold weather concreting;

in the emergency repair work.

In the past one of the commonly used materials as an accelerator was calcium chloride. But, now a days it is not used. Instead, some of the soluble carbonates, silicates fluosilicates and some of the organic compounds such as triethenolamine are used.

Accelerators such as fluosilicates and triethenolamine are used.

comparatively expensive. The recent studies have shown that calcium chloride is harmful for reinforced concrete and prestressed concrete. It may be used for plain cement concrete in comparatively high dose.

Some of the accelerators produced these days are so powerful that it is possible to make the cement set into stone hard in a matter of five minutes are

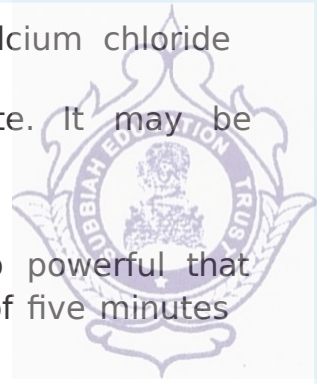

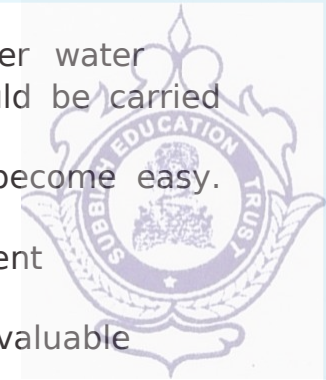

less. With the availability of such powerful accelerator, the under water concreting has become easy. Similarly, the repair work that would be carried out to the waterfront structures in the region of tidal variations has become easy. The use of such powerful accelerators have facilitated, the basement waterproofing operations. In the field of prefabrication also it has become an invaluable material.

As these materials could be used up to 10°C, they find an unquestionable use in cold weather concreting.

Some of the modern commercial accelerating materials are Mc-Schnell OC, Mc-Schnell SDS, Mc-Torkrethilfe BE, manufactured by Mc-Bauchemic (Ind) Pvt. Ltd. MC-Torkrethilfe BE is a material specially formulated to meet the demand for efficient and multifold properties desired for sprayed concrete and shotcreting operations. A field trial is essential to determine the dose for a given job and temperature conditions when the above materials are used.

Accelerating Plasticizers :

Certain ingredients are added to the concrete to accelerate the development of concrete to plasticizers or superplasticizers. Such accelerating superplasticizers, when added to concrete result in faster development of strength. The accelerating materials added to plasticizers or superplasticizers are triethanolamine, chloride, calcium nitrate, calcium nitrite, etc. The flouosilicates are accelerating plasticizers or super plasticizers manufactured by well known companies are chloride free.

3. Explain in detail about the plasticizers and super plasticizers.

These plasticizers can help the difficult conditions for obtaining higher workability without using excess of water. One must remember that addition

of excess water, will only improve the fluidity or the consistency but not the workability of concrete.

The excess water will not improve the inherent good qualities such as homogeneity and cohesiveness of the mix which reduces the tendency for segregation and bleeding. The use of superplasticizer has become almost an universal practice to reduce water/cement ratio for the given workability, which naturally increases the strength. The organic substances or combinations of organic and inorganic substances, which allow a reduction in water content for the given workability, or give a higher workability at the same water content, are termed as plasticizing admixtures. The advantages are considerable in both cases: in the former, concretes are stronger, and in the latter they are more workable.

The basic products constituting plasticizers are as follows:

- Anionic surfactants such as lignosulphonates and their modifications and derivatives, salts of sulphonates hydrocarbons.

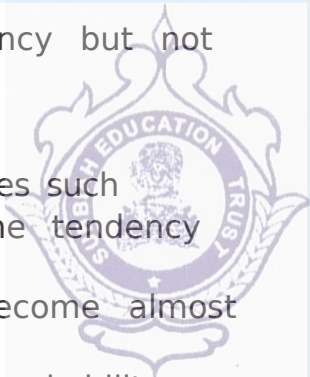

- Nonionic surfactants, such as polyglycol esters, acid of hydroxylated

carboxylic acids and their modifications and derivatives.

- Other products, such as carbohydrates etc. Among these, calcium, sodium and ammonium lignosulphonates are the most used.

Plasticizers are used in the amount of 0.1% to 0.4% by weight of cement. At these doses, at constant workability the reduction in mixing water is

expected to be of the order of 5% to 15%. This naturally increases the strength.

The increase in workability that can be expected, at the same w/c ratio, may

be anything from 30 mm to 150 mm slump, depending on the dosage, initial

slump of concrete, cement content and type. A good plasticizer fluidizes the mortar

or concrete in a different manner than that of the air-entraining agents.

Some

of the plasticizers, while improving the workability, entrains air also. As the entrainment of air reduces the mechanical strength, a good plasticizer is one

which does not cause air-entrainment in concrete more than 1 or 2%. Such a

product would allow adsorption into cement particles without any significant interferences with the hydration process or hydrated products. Normal water reducing admixtures may also be formulated from wholly synthetic raw materials.

Action of Plasticizers

The action of plasticizers is mainly to fluidify the mix and improve the workability of concrete, mortar or grout. The mechanisms that are involved

could be explained in the following way:

Dispersion. Portland cement, being in fine state of division, will have a tendency to flocculate in wet concrete. These flocculation entraps certain amount of water used in the mix and thereby all the water is not freely available to fluidify the mix.

When plasticizers are used, they get adsorbed on the cement particles.

The

adsorption of charged polymer on the particles of cement creates particle-to-

particle repulsive forces which overcome the attractive forces. This repulsive force is called Zeta Potential, which depends on the base, solid content,

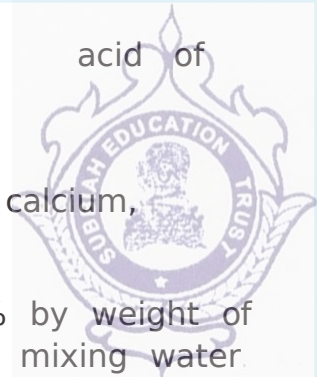

quantity of plasticizer used. The overall result is that the cement particles are deflocculated and dispersed.

When cement particles are deflocculated, the water trapped inside the flocks gets released and now available to fluidify the mix.

When cement particles get flocculated there will be inter particles friction between particle to particle and floc to floc. But in the dispersed condition there is water in between the cement particle and hence the inter particle friction is reduced.

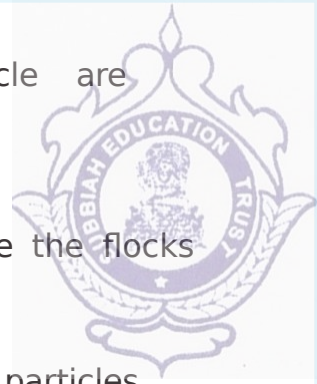

Retarding Effect.

It is mentioned earlier that plasticizer gets adsorbed on the surface of cement particles and form a thin sheath. This thin sheath inhibits the surface hydration reaction between water and cement as long as sufficient plasticizer molecules are available at the particle/solution interface.

The quantity of available plasticizers will progressively decrease as the polymers become entrapped in hydration products.

Many research workers explained that one or more of the following mechanisms may take place simultaneously:

- Reduction in the surface tension of water.
- Induced electrostatic repulsion between particles of cement.
- Lubricating film between cement particles.
- Dispersion of cement grains, releasing water trapped within cement flocs.
- Inhibition of the surface hydration reaction of the cement particles, leaving more water to fluidify the mix.
- Change in the morphology of the hydration products.
- Induced steric hindrance preventing particle-to-particle contact.

Super plasticizers (High Range Water Reducers)

They are chemically different from normal plasticizers. Use of super plasticizers permit the reduction of water to the extent upto 30 per cent without reducing workability in contrast to the possible reduction up to 15 per cent in case of plasticizers

The use of superplasticizer is practiced for production of flowing, self levelling, selfcompacting and for the production of high strength and high performance concrete. The mechanism of action of super plasticizers are more or less same as explained earlier in case of ordinary plasticizer.

Only thing is that the super plasticizers are more powerful as dispersing agents and they are high range water reducers. They are called High Range Water Reducers in American literature. It is the use of super plasticizer which has



made

it possible to use w/c as low as 0.25 or even lower and yet to make flowing concrete to obtain strength of the order 120 Mpa or more.

It is the use of super plasticizer which has made it possible to use fly ash, slag and particularly silica fume to high performance concrete.
make

Superplasticizers can produce:

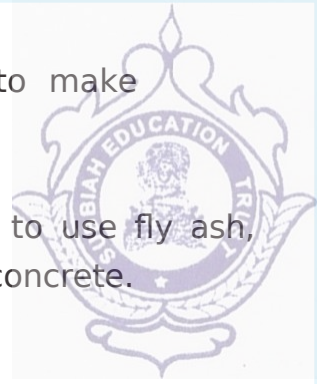



- at the same w/c ratio much more workable concrete than the plain ones,
- for the same workability, it permits the use of lower w/c ratio,
- as a consequence of increased strength with lower w/c ratio, it also permits a reduction of cement content.

The superplasticizers also produce a homogeneous, cohesive concrete generally without any tendency for segregation and bleeding.

Classification of Superplasticizer :

Following are a few polymers which are commonly used as base for superplasticizers.

- Sulphonated malanie-formaldehyde condensates (SMF)
- Sulphonated naphthalene-formaldehyde condensates (SNF)
- Modified lignosulphonates (MLS)

In addition to the above, in other countries the following new generation superplasticizers are also used.

- Acrylic polymer based (AP)
- Copolymer of carboxylic acrylic acid with acrylic ester (CAE)
- Cross linked acrylic polymer (CLAP)
- Polycarboxylate ester (PC)
- Multicarboxylate ethers (MCE)
- Combinations of above.

The first four categories of products differ and Plasticizers

superplasticizers are water based. The solid contents can vary to any extent in the products manufactured by different companies. Cost should be based on efficiencies and solid content, but not on volume or weight basis. Generally in projects cost

Effects of Superplasticizers on Fresh Concrete :

It is to be noted that dramatic improvement in workability is not showing up when plasticizers or superplasticizers are added to very stiff or what is

called

zero slump concrete at nominal dosages.

A mix with an initial slump of about 2 to 3 cm can only be fluidised by plasticizers or superplasticizers at nominal dosages. A high dosage is required to



fluidify no slump concrete. An improvement in slump value can be obtained to the

extent of 25 cm or more depending upon the initial slump of the mix, the dosage and cement content

4. Describe in detail about the water proofers.

Waterproofing admixtures may be obtained in powder, paste or liquid form and may consist of pore filling or water repellent materials. The chief materials in the pore filling class are silicate of soda, aluminium and zinc sulphates and aluminium and calcium chloride. These are chemically active pore fillers.

In addition they also accelerate the setting time of concrete and thus render the concrete more impervious at early age. The chemically inactive pore filling materials are chalk, fullers earth and talc and these are usually very finely ground. Their chief action is to improve the workability and to facilitate the reduction of water for given workability and to make dense concrete which is basically impervious.

Some materials like soda, potash soaps, calcium soaps, resin, vegetable oils, fats, waxes and coal tar residues are added as water repelling materials in this group of admixtures.

In some kind of waterproofing admixtures inorganic salts of fatty acids, usually calcium or ammonium stearate or oleate is added along with lime and calcium chloride. Calcium or ammonium stearate or oleate will mainly act as water repelling material, lime as pore filling material and calcium chloride accelerates the early strength development and helps in efficient curing of concrete all of which contribute towards making impervious concrete.

Some type of waterproofing admixtures may contain butyl stearate, the action of which is similar to soaps, but it does not give frothing action. Butyl stearate is superior to soap as water repellent material in concrete.

Heavy mineral oil free from fatty or vegetable oil has been proved to be effective in rendering the concrete waterproof. The use of Asphalt Cut-back

oils have been tried in quantities of 2 1/2

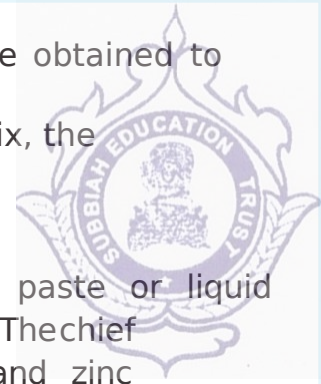

cement. Strength and workability of the concrete was not seriously affected.

Production of concrete of low permeability depends to a great extent on successful uniform placing of the material. An agent which improves the

plasticity of a given mixture without causing deleterious effects or which limits

bleeding and thereby the number of large voids might also be classified as a permeability reducing admixture.

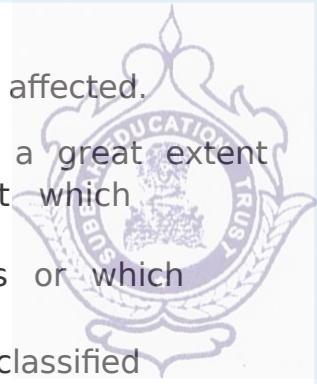

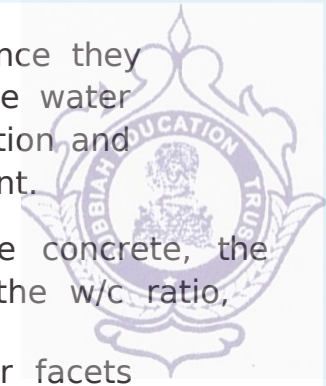

Air entraining agents may also be considered under this, since they increase workability and plasticity of concrete and help to reduce water content and bleeding. An air entrained concrete has lower absorption and capillarity till such time the air content do not exceed about 6 per cent.

Among many other aspects, the w/c ratio used in the concrete, the compaction, curing of concrete, the admixture used to reduce the w/c ratio, the heat of hydration, the micro-cracking of concrete and many other facets influence the structure of hardened cement paste and concrete, which will have direct bearing on permeability, damp-proofing and waterproofing.

5. Explain in detail about the GGBS and Metakaoline?

Metakaolin

Considerable research has been done on natural pozzolans, namely on thermally activated ordinary clay and kaolinitic clay. These unpurified materials have often been called —Metakaolin. Although it showed certain amount of pozzolanic properties, they are not highly reactive. Highly reactive metakaolin is made by water processing to remove unreactive impurities to make 100% reactive pozzolan. Such a product, white or cream in colour, purified, thermally activated is called High Reactive Metakaolin (HRM).

High reactive metakaolin shows high pozzolanic reactivity and reduction in Ca(OH)_2 even as early as one day. It is also observed that the cement paste undergoes distinct densification. The improvement offered by this densification includes an increase in strength and decrease in permeability.

The high reactive metakaolin is having the potential to compete with silica fume. Metakaolin is not a by product as any other pozzolanic material it is a specially manufactured material with definite properties.

Ground Granulated Blast Furnace Slag (GGBS)

Ground granulated blast-furnace slag is a nonmetallic product consisting

essentially of silicates and aluminates of calcium and other bases. The molten slag is rapidly chilled by quenching in water to form a glassy sand like granulated material. The granulated material when further ground to less than 45 micron will have specific surface of about 400 to 600 m²/ kg. The chemical composition of Blast

Furnace Slag (BFS) is similar to that of cement clinker. The blast furnace slag is mainly

used in India for manufacturing slag cement. There are two methods for making

Blast Furnace Slag Cement. In the first method blast furnace slag is interground

with cement clinker along with gypsum. In the second method blast furnace slag is

separately ground and then mixed with the cement. Clinker is hydraulically more active



than slag. It follows then that slag should be ground finer than clinker, in order to fully

develop its hydraulic potential. inter-grinding seriously restricts the flexibility to optimise slag level for different uses.

The hydraulic potential of both the constituents - clinker and slag can be fully

exploited if they are ground separately. The level of fineness can be controlled with

respect to activity, which will result in energy saving. The present trend is towards

separate grinding of slag and clinker to different levels.

Fly ash is used as an admixture in making concrete. Ground Granulated Blast-furnace Slag popularly called GGBS is used as an admixture in making concrete. In other countries its use as an admixture is more common than its use as slag cement.

6. Discuss the effects of adding fly ash, silica fume and GGBFS in concrete.

Fly ash

The most important benefit is reduced permeability to water and aggressive chemicals. Properly cured concrete made with fly ash creates a denser product because the size of the pores are reduced. This increases strength and reduces permeability. The use of fly ash can result in better workability, pumpability, cohesiveness, finish, ultimate strength, and durability. The fine particles in fly ash help to reduce bleeding and segregation and improve pumpability and finishing, especially in lean mixes.

Silica fume

Workability: With the addition of silica fume, the slump loss with time is directly proportional to increase in the silica fume content due to the introduction of large surface area in the concrete mix by its addition. Although the slump decreases, the mix remains highly cohesive.

Segregation and bleeding: Silica fume reduces bleeding significantly because the free water is consumed in wetting of the large surface area of the silica fume and hence the free water left in the mix for bleeding also decreases. Silica fume also blocks the pores in the fresh concrete so water within the concrete is not allowed to come to the surface.

GGBS

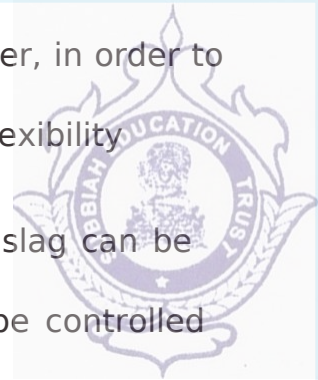

GGBS is used to make durable concrete structures in combination with ordinary portland cement and/or other pozzolanic materials. Two major uses of GGBS

are in the production of quality-improved slag cement, namely Portland Blast furnace

cement (PBFC) and high-slag blast-furnace cement (HSBFC), with GGBS content ranging typically from 30 to 70%; and in the production of ready-mixed or site-batched durable concrete.

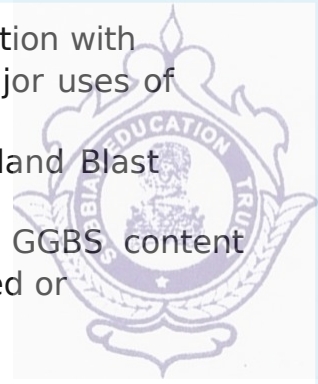

Concrete made with GGBS cement sets more slowly than concrete made with ordinary Portland cement, depending on the amount of GGBS in the cementitious material, but also continues to gain strength over a longer period in production conditions.

This

results in lower heat of hydration and lower temperature rises, and makes avoiding cold joints easier, but may also affect construction schedules where quick setting is required.

Use of GGBS significantly reduces the risk of damages caused by alkali-silica reaction

(ASR), provides higher resistance to chloride ingress — reducing the risk of

reinforcement corrosion — and provides higher resistance to attacks by sulfate and

other chemicals.

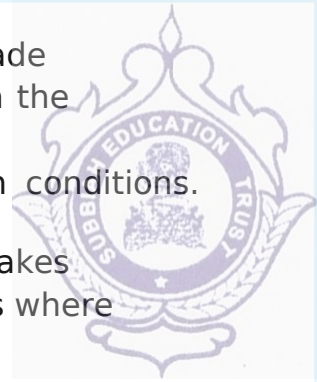



PROPORTIONING OF CONCRETE MIX

1. Give the types of concrete mixes.

- Nominal Mixes
- Standard mixes
- Designed Mixes

2. Define Nominal Mixes and its advantages.

Nominal mix is permitted by IS456:2000 for concrete of strength lower than

M25. In the past the specifications for concrete prescribed the proportions of

cement, fine and coarse aggregates. These mixes of fixed cement-aggregate ratio

which ensure adequate strength are termed nominal mixes. These offer

simplicity and under normal circumstances, have a margin of strength above that specified. However, due to the variability of mix ingredients the nominal

concrete for a given workability varies widely in strength.

3. Define Standard mixes.

The nominal mixes of fixed cement-aggregate ratio (by volume) vary widely in strength and may result in under- or over-rich mixes. For this reason, the minimum compressive strength has been included in many specifications. These mixes are termed standard mixes.

IS 456-2000 has designated the concrete mixes into a number of grades as M10, M15, M20, M25, M30, M35 and M40. In this designation the letter M refers to the mix and the number to the specified 28 day cube strength of mix in N/mm². The mixes of grades M10, M15, M20 and M25 correspond approximately to the mix proportions (1:3:6), (1:2:4), (1:1.5:3) and (1:1:2) respectively

4. What is Designed Mixes?

Design mix is permitted by IS 10262-1982 and IS456:2000 for concrete of strength greater than M25 is design mix.

5. What are the Factors affecting the choice of mix proportions?

The various factors affecting the mix design are:

- Compressive strength

Workability

Durability

Maximum nominal size of aggregate



- Grading and type of aggregate

- Quality Control

6. What are the Requirements of concrete mix design as per BIS?

The minimum compressive strength required from structural consideration

- The adequate workability necessary for full compaction with the compacting equipment available.
- Maximum water-cement ratio and/or maximum cement content to give adequate durability for the particular site conditions
- Maximum cement content to avoid shrinkage cracking due to temperature cycle in mass concrete

7. Define concrete mix design.

Concrete mix design is defined as the appropriate selection and proportioning of constituents to produce a concrete with pre-defined characteristics in the fresh and hardened states

8. Define Concrete Durability.

Durability of concrete is the ability of concrete to withstand the harmful effects of environment to which it will be subjected to, during its service life, without undergoing into deterioration beyond acceptable limits.

9. What is proportioning of concrete mix

Proportioning of concrete mix is the art of obtaining a suitable ratio of the various ingredients of concrete with the required properties at the lowest cost.

10. What is the principle of mix proportioning?

- a. Environmental exposure conditions
- b. Grades of concrete
- c. Type of cement
- d. Type and size of aggregates
- e. Nominal maximum size of aggregates
- f. Maximum and minimum cement content
- g. Maximum free water cement ratio by weight
- h. Degree of workability
- i. Air entrained agent
- j. Types of admixtures used if any
- k. Maximum/ minimum density of concrete
- l. Maximum/ minimum temperature of fresh concrete

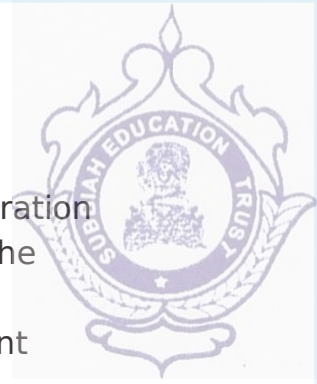

n. Source of water

11. Mention the properties related to mix design.

- a. Durability
- b. Workability
- c. Strength
- d. High strength concrete

12. Describe the physical properties of materials required to mix design

- a. Cement
- b. Aggregate
- c. Water
- d. Admixture

13. List out the advantages of Design mix

- a. Properties of all materials are used.
- b. Cement content is low and hence the mix design is economical.

14. List out the disadvantages of nominal mix

- a. Nominal mix does not say which type of sand, cement, aggregate to be used.
- b. High cement is required which leads to high cost.

15. What is ACI and the data used for ACI

American concrete institute was revised to include the use of entrained air.

- a. Fineness modulus
- b. Unit weight of dry rodded coarse aggregate
- c. Specific gravity of cement, coarse and fine aggregate
- d. Absorption characteristic of coarse and fine aggregate

16. Write any four methods of proportioning

- Arbitrary Method
- Fineness Modulus Method
- Minimum Void Method (Does not give satisfactory result)
- Maximum Density Method
- Water - Cement Ratio Method





PART B

ACI method

1. Design a concrete mix for construction of an elevated water tank. The specified design strength of concrete (characteristic strength) is 30 MPa at 28 days measured on standard cylinders. Standard deviation can be taken as 4 MPa. The specific gravity of FA and C.A. are 2.65 and 2.7 respectively. The dry rodded bulk density of C.A. is 1600 kg/m³, and fineness modulus of FA is 2.80. Ordinary Portland cement (Type I) will be used. A slump of 50 mm is necessary. C.A. is found to be absorptive to the extent of 1% and free surface moisture in sand is found to be 2 per cent. Assume any other essential data.

(a) Assuming 5 per cent of results are allowed to fall below specified design strength

$$\begin{aligned} \text{The mean strength,} \quad f_m &= f_{\min} + k_s \\ &= 30 + 1.64 \times 4 \\ &= 36.56 \\ &\text{say } 36.5 \text{ MPa} \end{aligned}$$

(b) Since OPC is used, from table 11.5, the estimated w/c ratio is 0.47.

This w/c ratio from strength point of view is to be checked against maximum w/c ratio given for special exposure condition given in Table 11.6 and minimum of the two is to be adopted.

From exposure condition Table 11.6, the maximum w/c ratio is 0.50

Therefore, adopt w/c ratio of 0.47

(c) From Table 11.8, for a slump of 50 mm, 20 mm maximum size of aggregate, for non-air-entrained concrete, the mixing water content is 185 kg/m³ of concrete. Also the approximate entrapped air content is 2 per cent.

$$\begin{aligned} \text{The required cement content} &= \frac{185}{0.47} \\ &= 394 \text{ kg/m}^3 \end{aligned}$$

(d) From Table 11.4, for 20 mm coarse aggregate, for fineness modulus of 2.80, the dry

rodded bulk volume of C.A. is 0.62 per unit volume of concrete.

(e) Therefore the weight of C.A. = 0.62 × 1600





(f) From Table 11.9, the first estimate of density of fresh concrete for 20 mm maximum size of aggregate and for non-air-entrained concrete = 2355 kg/m³

(g) The weight of all the known ingredient of concrete

$$\text{weight of water} = 185 \text{ kg/m}^3$$

$$\text{weight of cement} = 394 \text{ kg.m}^3$$

$$\text{weight of C.A.} = 992 \text{ kg/m}^3$$

$$\text{weight of F.A.} = 2355 - (185 + 394 + 992)$$

$$= 784 \text{ kg/m}^3$$

(h) Alternatively the weight of F.A. can also be found out by absolute volume method which is more accurate, as follows.

Tabulate the absolute volume of all the known ingredients

<u>Item number</u>	<u>Ingredients</u>	<u>Weight</u> kg/m ³	<u>Absolute volume</u> cm ³
1.	<u>Cement</u>	<u>394</u>	$\frac{394}{3.15} \times 10^3 = 125 \times 10^3$
2.	<u>Water</u>	<u>185</u>	$\frac{185}{1} \times 10^3 = 185 \times 10^3$
3.	<u>Coarse Aggregate</u>	<u>992</u>	$\frac{992}{2.7} \times 10^3 = 367 \times 10^3$
4.	<u>Air</u>	<u>2</u>	$\frac{2}{100} \times 10^6 = 20 \times 10^3$

$$\text{Total absolute volume} = 697 \times 10^3 \text{ cm}^3$$

Therefore absolute volume of F.A.

$$= (1000 - 697) \times 10^3$$

$$= 303 \times 10^3$$

$$\text{Weight of FA} = 303 \times 2.65$$

$$= 803 \text{ kg/m}^3$$

Adopt F.A = 803

kg/m³.

(i) Estimated quantities of materials per cubic meter of concrete are

Cement = 394 kg

F.A = 803 kg

C.A = 992 kg

Water = 185 kg

Density of fresh concrete 2374 kg/m³ as against 2355 read from Table 11.9

(j) Proportions

<u>C:</u>		<u>F.</u>	:	<u>C.A</u>	:	<u>water</u>
	394	<u>A</u>	:	992	:	185
	<u>1</u>	803	:	<u>2.52</u>	:	<u>0.47</u>

Weight of materials for one bag mix in kg = 50 : 102 : 126 : 23.5

The above quantities is on the basis that both F.A and C.A are in saturated and surface dry condition (SSD conditions).

(k) The proportions are required to be adjusted for the field conditions. FA has surface moisture of 2 per cent

$$\text{◆ Total free surface moisture in FA} = \frac{2}{100} \times 803 = 16.06 \text{ kg/m}^3$$

Weight of F.A in field condition = 803 + 16.06 = 819.06 kg/m³

say 819 kg/m³

C.A absorbs 1% water

□ Quantity of water absorbed by = 9.92 kg/m³

$$\text{◆ Weight of C.A in field condition} = 992 - 9.92$$

$$= 982.08 \text{ kg/m}^3$$



With regard to water, 16.06 kg of water is contributed by F.A and 9.92 kg of water is absorbed by C.A.

Therefore $16.06 - 9.92 = 6.14$ kg of extra water is contributed by aggregates. This quantity of water is deducted from Total water

i.e.,

$$185.00 - 6.14 = 178.86 \text{ kg/m}^3$$

say 179 kg/m³

(I) Quantities of materials to be used in field duly corrected for free surface moisture in F.A and absorption characteristic of C.A

[Cement = 394 kg/m³](#)

[F.A. = 819 kg/m³](#)

[C.A. = 982 kg/m³ Water = 179 kg/m³](#)

[Field density of fresh concrete = 2374 kg/m³](#)

2. Illustrative Example of Concrete Mix Design (Grade M 20) (

a) Design stipulations

(i) Characteristic compressive strength

required in the field at 28 days.

20 MPa

(ii) Maximum size of aggregate

20 mm (angular)

(iii) Degree of workability

0.90 compacting factor

(iv) Degree of quality control

Good

(v) Type of Exposure

Mild

(b)

Test data for Materials

(i) Specific gravity of cement

3.15



(ii) Compressive strength of cement at
7 days 269-1989

Satisfies the requirement of IS:

(iii) 1. Specific gravity of coarse
aggregates

2.60



2. Specific gravity of fine aggregates 2.60

(iv) Water absorption:

- 1. Coarse aggregate 0.50 %
- 2. Fine aggregate 1.0%

(v) Free (surface) moisture:

- 1. Coarse aggregate Nil
- 2. Fine aggregate 2.0%

(vi) Sieve analysis is shown below:

1. Coarse aggregate

Sieve size (mm)	Analysis of Coarse aggregate fractions (% passing)		Percentage of different Fractions			Remark
	III	60%	II 40%	40	Combined 100%	
20	100	100	60	10		Conforming to Table 2.
10	0	71.20	0	28.5	28.5	
						IS: 383—
4.75		9.40	=	3.7	3.7	1970
2.36	=	=	=	=	=	

2. Fine aggregate

Sieve sizes	Fine aggregate (% passing)	Remarks
4.75 mm	100	
2.36 mm	100	Conforming to grading
1.18 mm	93	Zone III of Table 4
600 micron	60	IS: 385–1970
300 micron	12	
150 micron	2	





(c) Target mean strength of concrete

The target mean strength for specified characteristic cube

$$\text{strength is } 20 + 1.65 \times 4 = 26.6 \text{ MPa}$$

(refer Table 11.21 and Table 11.22 for values of t and s)

(d) Selection of water-cement ratio

From Fig. 11.10 the water-cement ratio required for the target mean strength of 26.6 MPa is 0.50. This is lower than the maximum value of 0.55 prescribed for 'Mild' exposure. (refer Table 9.18) adopt W/C ratio of 0.50.

(e) Selection of water and sand content

From Table 11.24, for 20 mm maximum size aggregate, sand conforming to grading Zone II, water content per cubic metre of concrete = 186 kg and sand content as percentage of total aggregate by absolute volume = 35 per cent.

For change in value in water-cement ratio, compacting factor, for sand belonging to Zone III, following adjustment is required.

<i>Change in Condition</i>	<i>Per cent adjustment required</i>	
	<i>Water content</i>	<i>Sand in total aggregate</i>
<i>(See Table 11.26)</i>		
<i>For decrease in water-cement ratio by (0.60–0.50) that is 0.10.</i>		– 2.0
<i>0</i>		– 1.5
<i>For increase in compacting factor (0.9–0.8), that is 0.10</i>	+	– 3.5
<i>3 For sand conforming to Zone III of Table 4, IS: 383–1970</i>		0
	<i>Total</i>	<i>+ 3</i>

Therefore, required sand content as percentage of total aggregate by absolute volume

$$= 35 - 3.5 = 31.5\%$$

Required water
content

$$= 186 + 5.58 = 191.6 \text{ l/m}^3$$



(f) Determination of cement content

Water-cement ratio = 0.50

water = 191.6 litre

$$\text{cement} = \frac{191.6}{0.50} = 383 \text{ kg/m}^3$$

This cement content is adequate for 'mild' exposure condition.

(g) Determination of coarse and fine aggregate contents

From Table 11.23, for the specified maximum size of aggregate of 20 mm, the amount of entrapped air in the wet concrete is 2 per cent.

Taking this into account and applying

[equations. 1 and 2 given on page 494.](#)

$$0.98 = \frac{191.6 + \frac{383}{3150} + 1}{1 + \frac{fa}{1000}} \times \frac{fa}{1000}$$

$fa = 546 \text{ kg/m}^3$, and

$$Ca = \frac{1.0315}{0.315} \times \frac{26}{546} = 2.6$$

$fa = 546 \text{ kg/m}^3$, and $Ca = 1188 \text{ kg/m}^3$.

The mix proportion then becomes:

Water		Fine aggregate		Coarse Aggregate
Cement				
191.6	383	546		1188 kg
	kg	kg		
0.50	: 1	: 1.425	:	3.10

(h) Actual quantities required for the mix per bag of cement

The mix is 0.50 : 1 : 1.425 : 3.10. For 50 kg of cement, the quantity of materials are worked out as below:

(i) Cement = 50 kg







(iii) Coarse aggregate =
155 kg

Fraction I = 60% = 93 kg
Fraction II = 40% = 62 kg

(iv) Water

1. for w/c ratio of 0.50, quantity = 25 litres of water.
2. Extra quantity of water to be added for absorption in case of CA, at 0.5 percent mass. = 0.77 litres
3. Quantity of water to be deducted for moisture present in sand, at 2 per cent by mass. = 1.42 litres

Actual quantity of water required to be added

$$= 25.0 + 0.77 - 1.42$$

$$= 24.35 \text{ litres.}$$

(i) Actual quantity of sand required after = 71.0 + 1.42 allowing for mass of free moisture = 72.42 kgs.

(j) Actual quantity of CA required

$$\text{Fraction I} = 93 - 0.46 = 92.54 \text{ kg}$$

$$\text{Fraction II} = 62 - 0.31 = 61.69 \text{ kg}$$

Therefore, the actual quantities of different constituents required for one bag mix are

<u>Water</u>	:	<u>24.35 kg</u>
Cement	:	50.00 kg
Sand	:	72.42 kg
CA Fraction I	:	92.54 kg
Fraction II	:	61.69 kg



3. Explain the concept of mix design and Mention the method of proportioning?

Concept of Mix Design

It will be worthwhile to recall at this stage the relationships between aggregate and paste which are the two essential ingredients of concrete. Workability of the mass is provided by the lubricating effect of the paste and is influenced by the amount and dilution of paste.

The strength of concrete is limited by the strength of paste, since mineral aggregates with rare exceptions, are far stronger than the paste compound. Essentially the permeability of concrete is governed by the quality and continuity of the paste, since little water flows through aggregate either under pressure or by capillarity.

Further, the predominant contribution to drying shrinkage of concretes is that of paste. Since the properties of concrete are governed to a considerable extent by the quality of paste, it is helpful to consider more closely the structure of the paste. The fresh paste is a suspension, not a solution of cement in water. The more dilute the paste, the greater the spacing between cement particles, and thus the weaker will be the ultimate paste structure. The other conditions being equal, for workable mixes, the strength of concrete varies as an inverse function of the water/cement ratio.

Since the quantity of water required also depends upon the amount of paste, it is important that as little paste as possible should be used and hence the importance of grading.

Variables in Proportioning With the given materials, the four variable factors to be considered in connection with specifying a concrete mix are:

- (a) Water-Cement ratio
- (b) Cement content or cement-aggregate ratio

(c) Gradation of the aggregates

(d) Consistency.

In general all four of these inter-related variables cannot be chosen or manipulated arbitrarily. Usually two or three factors are specified, and the others are adjusted to give minimum workability and economy.

Water/cement ratio expresses the dilution of the paste-cement content varies directly with the amount of paste. Gradation of aggregate is controlled by varying the amount of given fine and coarse aggregate. Consistency is established by practical



requirements of placing. In brief, the effort in proportioning is to use a minimum amount of paste (and therefore cement) that will lubricate the mass while fresh and after hardening will bind the aggregate particles together and fill the space between them.

Any excess of paste involves greater cost, greater drying shrinkage, greater susceptibility to percolation of water and therefore attack by aggressive waters and weathering action. This is achieved by minimizing the voids by good gradation.

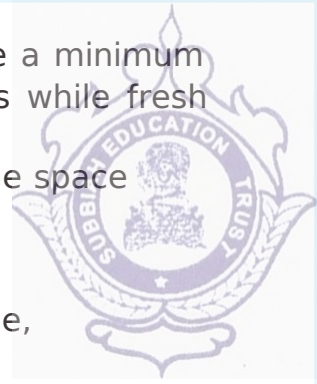

Various Methods of Proportioning

- (a) Arbitrary proportion
- (b) Fineness modulus method
- (c) Maximum density method
- (d) Surface area method
- (e) Indian Road Congress, IRC 44 method
- (f) High strength concrete mix design
- (g) Mix design based on flexural strength
- (h) Road note No. 4 (Grading Curve method)
- (i) ACI Committee 211 method
- (j) DOE method
- (k) Mix design for pumpable concrete
 - (l) Indian standard Recommended method IS 10262-82

Out of the above methods, some of them are not very widely used these days because of some difficulties or drawbacks in the procedures for arriving at the satisfactory proportions. The ACI Committee 211 method, the DOE method and Indian standard recommended methods are commonly used.

4. Explain the design procedure of ACI method of mix design?

The ACI Committee mix design method assume certain basic

facts which have been substantiated by field experiments or large works.

They are:

(a) The method makes use of the established fact, that over a considerable range of practical proportions, fresh concrete of given slump and containing a reasonably well graded aggregate of given maximum size will have

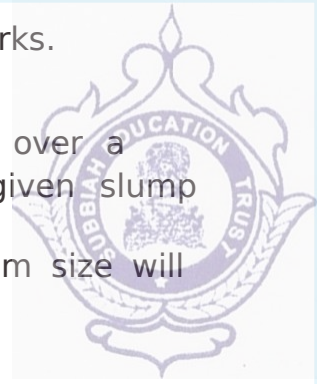

practically a constant total water content regardless of variations in water/cement ratio

and cement content, which are necessarily interrelated.

(b) It makes use of the relation that the optimum dry rodded volume of coarse

aggregate per unit volume of concrete depends on its maximum size and the fineness modulus of the fine aggregate as indicated in Table 11.4 regardless of

shape of particles. The effect of angularity is reflected in the void content, thus

angular coarse aggregates require more mortar than rounded coarse aggregate.

(c) Irrespective of the methods of compaction, even after complete compaction is done, a definite percentage of air remains which is inversely proportional to the maximum size of the aggregate.

The following is the procedure of mix design in this method:

(a) Data to be collected :

(i) Fineness modulus of selected F.A.

(ii) Unit weight of dry rodded coarse aggregate.

(iii) Sp. gravity of coarse and fine aggregates in SSD condition

(iv) Absorption characteristics of both coarse and fine

aggregates. (v) Specific gravity of cement.

(b) From the minimum strength specified, estimate the average design strength

either by using standard deviation or by using coefficient of variation.

(c) Find the water/cement ratio from the strength point of view. Find also the

water/cement ratio from durability point of view. Adopt lower value out of strength consideration and durability consideration.

(d) Decide maximum size of aggregate to be used. Generally for RCC work 20 mm and prestressed concrete 10 mm size are used.

(e) Decide workability in terms of slump for the type of job in hand.

(f) The total water in kg/m^3 of concrete is read from table 11.8 entering the

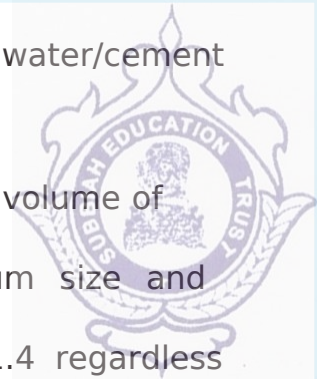

table with the selected slump and selected maximum size of aggregate. Table 11.8

also gives the approximate amount of accidentally entrapped air in non-air-entrained concrete.

(g) Cement content is computed by water/cement ratio.

dividing the total water content

by the

(h) The bulk volume of dry rodded coarse aggregate per unit volume of concrete is



selected, for the particular maximum size of coarse aggregate and fineness modulus of fine aggregate.

(j) The weight of C.A. per cubic meter of concrete is calculated by multiplying the bulk volume with bulk density.

(k) The solid volume of coarse aggregate in one cubic meter of concrete is calculated by knowing the specific gravity of C.A.

(l) Similarly the solid volume of cement, water and volume of air is calculated in one cubic meter of concrete.

(m) The solid volume of sand is computed by subtracting from the total volume of concrete the solid volume of cement, coarse aggregate, water and entrapped air.

(n) Weight of fine aggregate is calculated by multiplying the solid volume of fine aggregate by specific gravity of F.A.

5. Explain in detail about the method of concrete mix design.

Indian Standard Recommended Method of Concrete Mix Design (IS 10262 – 1982)

The Bureau of Indian Standards, recommended a set of procedure for design of concrete mix mainly based on the work done in national laboratories. The mix design procedures are covered in IS 10262-82. The methods given can be applied for both medium strength and high strength concrete. Before we proceed with

describing this method step by step, the following shortcomings in this method are

pointed out. Some of them have arisen in view of the revision of IS 456- 2000. The

procedures of concrete mix design needs revision and at this point of time (2000 AD) a committee has been formed to look into the matter of Mix Design.

(i) The strength of cement as available in the country today has greatly improved since 1982. The 28-day strength of A, B, C, D, E, F, category of cement is day to be reviewed.

(ii) The graph connecting, different strength of cements and W/C is to be re-established.

(iii) The graph connecting 28-day compressive strength of concrete and W/C ratio is to be extended up to 80 MPa, if this graph is to cater for high strength concrete. (iv) As per the revision of IS 456-2000, the

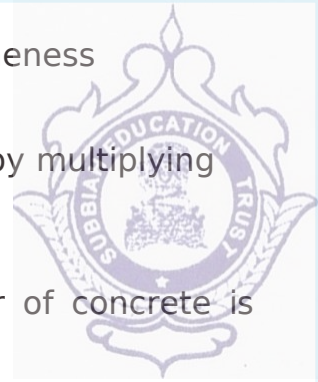

degree of workability is expressed

in terms of slump instead of compacting factor. This results in change of values in estimating approximate sand and water contents for normal concrete up to 35 MPa and high strength concrete above 35 MPa.

(v) In view of the above and other changes made in the revision of IS 456-2000, the mix design procedure as recommended in IS 10262-82 is required to be

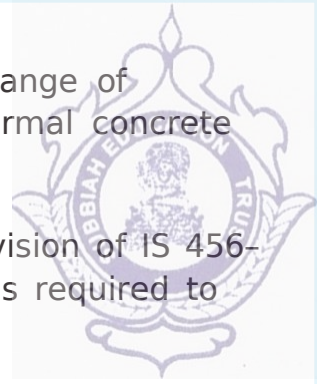

modified to the extent considered necessary and examples of mix design is worked out. However, in the absence of revision of Indian Standard on method of Mix Design, the existing method i.e., IS 10262 of 1982 is described below step by step. Wherever it is possible, the new information given in IS 456 of 2000 have been incorporated and the procedure is modified to that extent.



(a) Target mean strength for mix design: The target mean compressive (f_{ck}) strength at 28 days is given by

$$\bar{f}_{ck} = f_{ck} + tS$$

where f_{ck} = characteristic compressive strength at 28 days.

S is the standard deviation. The value of the standard deviation has to be worked out from the trials conducted in the laboratory or field. As soon as enough test results become available, standard deviation should be worked out and the mix design is modified accordingly.

t = a statistical value depending on expected proportion of low results (risk factor).

According to IS: 456-2000 and IS: 1343-'80, the characteristic strength is defined as

that value below which not more than 5 per cent results are expected to fall, in

which case the above equation reduces to

(b) Selection of Water/Cement ratio

Various parameters like types of cement, aggregate, maximum size of aggregate, surface texture of aggregate etc. are influencing the strength of concrete,

when water/cement ratio remain constant, hence it is desirable to establish a relation between concrete strength and free water cement ratio with materials and condition to be used actually at site.

(c) Estimation of Entrapped Air.

The air content is estimated from Table for the normal maximum size of aggregate used.



Maximum Size of Aggregate (mm)	Entrapped Air, as % of Volume of Concrete
10	3.0
20	2.0
40	1.0



(d) Selection of Water Content and Fine to Total Aggregate ratio

(a) Crushed (Angular) coarse aggregate, conforming to IS: 383—'70.

(b) Fine aggregate consisting of natural sand conforming to grading zone II of Table of IS: 383—'70.

(c) Workability corresponds to compacting factor of 0.80 (Slump 30 mm approximately)

(e) Calculation of Cement Content. The cement content per unit volume of concrete may be calculated from free water-cement ratio and the quantity of water per unit

volume of concrete (cement by mass = Water content/Water cement ratio).

(f) Calculation of aggregate content. Aggregate content can be determined from the following equations:

$$V = \left[W + \frac{C}{S_c} + \frac{1}{P} \frac{f_a}{S_{fa}} \right] \frac{1}{1000}$$

$$C_a = \frac{1-P}{P} \times f_a \times \frac{S_{ca}}{S_{fa}}$$

Where

V = absolute volume of fresh concrete, which is equal to gross volume (m³) minus the volume of entrapped air,

W = Mass of water (kg) per m³ of

concrete C = Mass of cement (kg) per

m³ of concrete S_c = Specific gravity of

cement

P = Ratio of FA to total aggregate by absolute volume

f_a, C_a = Total masses of FA and CA (kg) per m³ of concrete respectively and

S_{fa}, S_{ca} = Specific gravities of saturated, surface dry fine aggregate and coarse aggregate respectively.

(g) Actual quantities required for mix. It may be mentioned that above mix proportion has been arrived at on the assumption that aggregates are saturated and surface dry.



For any deviation from this condition i.e., when aggregate are moist or air dry or bone dry, correction has to be applied on quantity of mixing water as well to the aggregate.

(h) The calculated mix proportions shall be checked by means of trial batches. Quantities of material for each trial shall be enough for at least three 150 mm size cubes and concrete required to carry out workability test according to IS: 1199-'59.

6. What are the Factors affecting the proportioning of concrete mix?

The various factors affecting the mix design are:

1. Compressive strength

It is one of the most important properties of concrete and influences many other

describable properties of the hardened concrete. The mean compressive strength

required at a specific age, usually 28 days, determines the nominal water-cement ratio of the mix. The other factor affecting the strength of concrete at a given age and cured at a prescribed temperature is the degree of compaction. According to Abraham's law the strength of fully compacted concrete is inversely proportional to the water-cement ratio.

2. Workability

The degree of workability required depends on three factors. These are the size of the section to be concreted, the amount of reinforcement, and the method of compaction to be used. For the narrow and complicated section with numerous corners or inaccessible parts, the concrete must have a high workability so that full compaction can be achieved with a reasonable amount of effort. This also applies to the embedded steel sections. The desired workability depends on the compacting equipment available at the site.

3. Durability

The durability of concrete is its resistance to the aggressive environmental conditions.

High strength concrete is generally more durable than low strength concrete. In the

situations when the high strength is not necessary but the conditions of exposure are

such that high durability is vital, the durability requirement will determine the water-

cement ratio to be used.

4. Maximum nominal size of aggregate

In general, larger the maximum size of aggregate, smaller is the cement requirement for

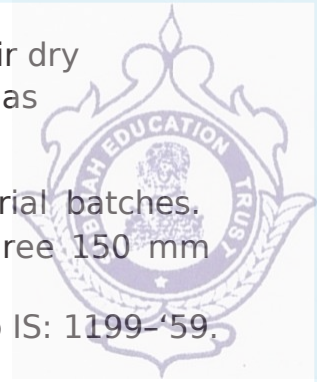

a particular water-cement ratio, because the workability of concrete increases with increase in maximum size of the aggregate. However, the compressive strength tends to increase with the decrease in size of aggregate. IS 456:2000 and IS 1343:1980 recommend that the nominal size of the aggregate should be as large as possible.

5. Grading and type of aggregate

The grading of aggregate influences the mix proportions for a specified workability and

water-cement ratio. Coarser the grading leaner will be mix which can be used. Very

lean mix is not desirable since it does not contain enough finer material to make the concrete cohesive.

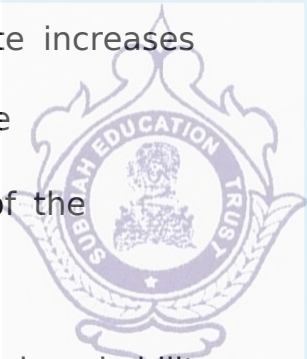

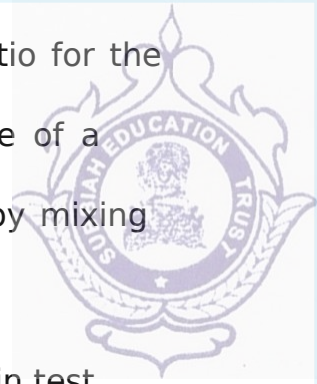

The type of aggregate influences strongly the aggregate-cement ratio for the desired

workability and stipulated water cement ratio. An important feature of a satisfactory

aggregate is the uniformity of the grading which can be achieved by mixing different

size fractions.

6. Quality Control

The degree of control can be estimated statistically by the variations in test results. The variation in strength results from the variations in the properties of the mix ingredients

and lack of control of accuracy in batching, mixing, placing, curing and testing. The

lower the difference between the mean and minimum strengths of the mix lower will be the cement-content required. The factor controlling this difference is termed as quality control.

FRESH AND HARDENED PROPERTIES OF CONCRETE**1. Define workability.**

Workability is the property of

concrete which determines the amount of

internal

work necessary to produce full compaction. It is a measure with which concrete can be handled from the mixer stage to its final fully compacted stage.

2. List out the requirements of fresh concrete.

- a. Mixability
- b. Stability

Mobility

[Compactability](#)

[Finishability](#)

List out the Factors affecting Workability?

[Water content](#)

[Mix proportion](#)

[Size of aggregate](#)

[Shape of aggregate](#)

[Surface texture](#)

[Grading](#)

[Admixture](#)

Mention the methods to measure the workability?

[Slump Test](#)

- b. Compaction Factor
- c. Vee-Bee Consistometer
- d. Kelly Ball Penetration test
- e. Flow table Test
- f. Vibrating table

5. Mention the values of different type of slump.

- True slump
- Collapse slump
- Shear slump

- up to 125mm from top

- up to 150 mm from top

-150-225mm



**6. List out the usage of slump values**

- slump 0 - 25 mm are used in road making
- 10 - 40 mm are used for foundations with light reinforcement
- 50 - 90 for normal reinforced concrete placed with vibration

7. Define compaction factor?

Compaction Factor is the ratio of the weight of partially compacted concrete to the weight of the concrete when fully compacted in the same mould.

8. Define Vee bee consistometer

Consistometer is based on consistency test which is a mechanical variation of the simple slump test which includes determination of the workability of concrete. Measures consistency of concrete in terms of time required to transform by vibration a frustum of fresh concrete sample into a cylinder. This time is called VB time.

9. What is the use of Kelly Ball Penetration test

Kelly Ball Penetration method is used to determine the penetration of a hemispherical metal weight into freshly mixed concrete, which is related to the workability of the concrete.

10. What is the use of flow table method?

Flow table indicates consistency and proneness to segregation. It is used for aggregate of size $<40\text{mm}$. The flow is determined by $= \{D-250/250\} * 100$.

11. Mention the test conducted to test the properties of hardened concrete.

- a. Compression Testing Machine
- b. Flexure Strength Testing Machine
- c. Lateral Extensometer
- d. Split Tensile Test
- e. Shear strength
- f. Bond strength

12. List out the factors affecting the results of strength test.

- a. Size and shape of aggregate
- b. Condition of casting
- c. Moisture condition
- d. Bearing condition
- e. Rate of loading

13. What are the steps adopted to control bleeding.

By adding more cement

By using more finely ground

cement By using little air

entraining agent

By increasing finer part of fine aggregate

By properly designing the mix and using minimum quantity of water.

14. Define Segregation.

The tendency of separation of coarse aggregate grains from the concrete mass is called segregation.

15. Define bleeding.

The tendency of water to rise to the surface of freshly laid concrete is known as bleeding.





1. Define workability? Explain the factors affecting

workability? Workability

The lubrication required for handling concrete without segregation, for placing without loss of homogeneity, for compacting with the amount of efforts forthcoming and to finish it sufficiently easily, the presence of a certain quantity of water is of vital importance. The quality of concrete satisfying the above requirements is termed as workable concrete.

Factors Affecting Workability

Workable concrete is the one which exhibits very little internal friction between particle and particle or which overcomes the frictional resistance offered by the formwork surface or reinforcement contained in the concrete with just the amount of compacting efforts forthcoming. The factors helping concrete to have more lubricating effect to reduce internal friction for helping easy compaction are given below:

- | | |
|----------------------------------|------------------------|
| (a) Water Content | (b) Mix Proportions |
| (c) Size of Aggregates | (d) Shape of |
| (e) Surface Texture of Aggregate | (f) Aggregates |
| (g) Use of Admixtures. |) Grading of Aggregate |

(a) Water Content: Water content in a given volume of concrete, will have significant influences on the workability. The higher the water content per cubic meter of concrete, the higher will be the fluidity of concrete, which is one of the important factors affecting workability.

(b) Mix Proportions: Aggregate/cement ratio is an important factor influencing workability. The higher the aggregate/cement ratio, the leaner is the concrete.

On

the other hand, in case of rich concrete with lower aggregate/cement ratio, more paste is available to make the mix cohesive and fatty to give better workability.

(c) Size of Aggregate: The bigger the size of the aggregate, the less is the surface area and hence less amount of water is required for wetting the surface and less matrix or paste is required for lubricating the surface to reduce internal friction.

(d) Shape of Aggregates: The shape of aggregates influences workability in good measure. Angular, elongated or flaky aggregate makes the concrete very harsh when compared to rounded aggregates or cubical shaped aggregates. Contribution to better workability of rounded aggregate will come from the fact that for the given

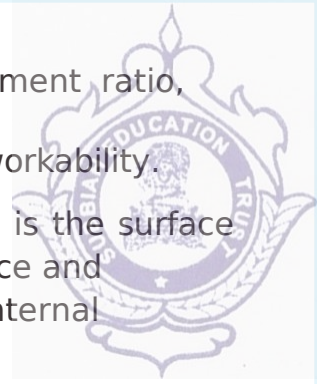

volume or weight it will have less surface area and less voids than angular or flaky aggregate.

(e) Surface Texture: The influence of surface texture on workability is again due to the fact that the total surface area of rough textured aggregate is more than the surface

area of smooth rounded aggregate of same volume. A reduction of inter-particle

frictional resistance offered by smooth aggregates also contributes to higher workability.

(f) Grading of Aggregates: This is one of the factors which will have maximum influence on workability. A well graded aggregate is the one which has least amount

of voids in a given volume. Aggregate particles will slide past each other with the

least amount of compacting efforts. The better the grading, the less is the void

content and higher the workability. The above is true for the given amount of paste volume.

(g) Use of Admixtures: Of all the factors mentioned above, the most important factor which

affects the workability is the use of admixtures. It is to be noted that initial slump of

concrete mix or what is called the slump of reference mix should be about 2 to 3 cm

to enhance the slump many fold at a minimum dose. One should manipulate other

factors to obtain initial slump of 2 to 3 cm in the reference mix. Without initial slump

of 2 -n 3 cm, the workability can be increased to higher level but it requires higher

dosage - hence uneconomical. Use of air-entraining agent being surface-active, reduces

the internal friction between the particles. They also act as artificial fine aggregates of very smooth surface.

2. Explain the test for

workability? Measurement of

Workability

Workability of concrete is a complex

Numerous attempts have been

made by many research workers to quantitatively measure this important and

property of concrete. Some of the tests, measure the parameters very close to workability and provide useful information. The following tests are commonly employed to measure workability

- (a) Slump Test
- (b) Compacting Factor Test
- (c) Flow Test
- (d) Kelly Ball Test
- (e) Vee Bee Consistometer Test.



Slump Test

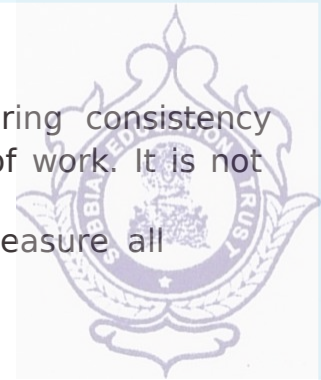

- Slump test is the most commonly used method of measuring consistency of concrete which can be employed either in laboratory or at site of work. It is not a suitable method for very wet or very dry concrete. It does not measure all factors contributing to workability, nor is it always representative of the placability of the concrete.

- Repeated batches of the same mix, brought to the same slump, will have the same water content and water cement ratio, provided the weights of aggregate, cement and admixtures are uniform and aggregate grading is within acceptable limits.

- Additional information on workability and quality of concrete can be obtained

by observing the manner in which concrete slumps. Quality of concrete can also be

further assessed by giving a few tamping or blows by tamping rod to the base plate.

The deformation shows the characteristics of concrete with respect to tendency for

segregation. The apparatus for conducting the slump test essentially consists of a

metallic mould in the form of a frustum of a cone having the internal dimensions as under:

Bottom diameter r: 20 cm
 Top diameter : 10 cm
 Height : 30 cm



Collapse

Shear
Types of slump

True slump

The thickness of the metallic sheet for the mould should not be thinner than 1.6 mm. Sometimes the mould is provided with suitable guides for lifting vertically up. For

tamping the concrete, steel tamping rod 16 dia 0.06 m along
mm , 6 er

a

with bullet end is used. The internal surface of the mould is thoroughly cleaned and freed from superfluous moisture and adherence of any old set concrete before commencing the test. The mould is placed on a smooth, horizontal, rigid and non-absorbant surface. The mould is then filled in four layers, each approximately 1/4 of the height of the mould. Each layer is tamped 25 times by the tamping rod taking care to distribute the strokes evenly over the cross section. After the top layer has been rodded, the concrete is struck off level with a trowel and tamping rod. The mould is

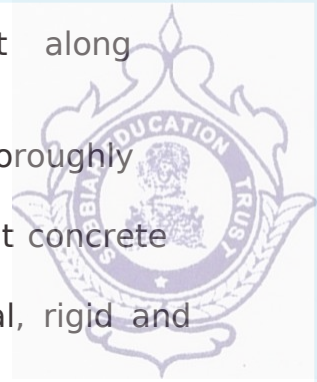

removed from the concrete immediately by raising it slowly and carefully in a vertical direction. This allows the concrete to subside. This subsidence is referred as SLUMP of concrete. The difference in level between the height of the mould and that of the highest point of the subsided concrete is measured. This difference in height in mm. is taken as Slump of Concrete. Shear slump also indicates that the concrete is non-cohesive and shows the characteristic of segregation. It is seen that the slump test gives fairly good consistent results for a plastic-mix. This test is not sensitive for a stiff-mix. In case of dry-mix, no variation can be detected between mixes of different workability. In the case of rich mixes, the value is often satisfactory, their slump being sensitive to variations in workability.

K-SLUMP TESTER

It can be used to measure the slump directly in one minute after the tester is inserted in the fresh concrete to the level of the floater disc. This tester can also be used to measure the relative workability. A chrome plated steel tube with external and internal diameters of 1.9 and 1.6 cm respectively. The tube is 25 cm long and its lower part is used to make the test. The length of this part is 15.5 cm which includes the solid cone that facilitates inserting the tube into the concrete.

Two types of openings are provided in this part: 4 rectangular slots 5.1 cm long and 0.8 cm wide and 22 round holes 0.64 cm in diameter; all these openings are distributed uniformly in the lower part.

A disc floater 6 cm in diameter and 0.24 cm in thickness which divides the tube into two parts: the upper part serves as a handle and the lower one is for testing as already mentioned. The disc serves also to prevent the tester from sinking into the concrete beyond the preselected level.

A hollow plastic rod 1.3 cm in diameter and 25 cm long which

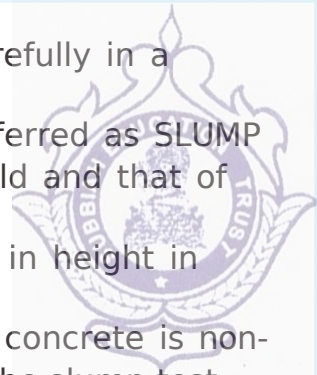

contains a graduated scale in centimeters. This rod can move freely inside the tube and can be used to measure the height of mortar that flows into the tube and stays there. The rod is plugged at each end with a plastic cap to prevent concrete or any other material from seeping inside.

An aluminium cap 3 cm diameter and 2.25 cm long which has a little hole and a screw that can be used to set and adjust the reference zero of the apparatus. There is also in the upper part of the tube, a small pin which is used to support the measuring rod at the beginning of the test. The total weight of the apparatus is 226 g.

The following procedure is used:

(a) Wet the tester with water and shake off the excess.

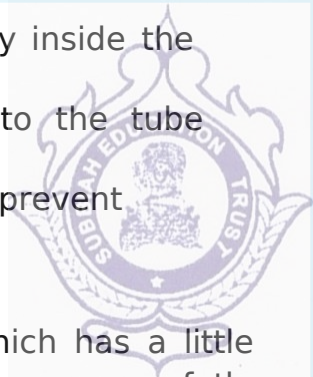

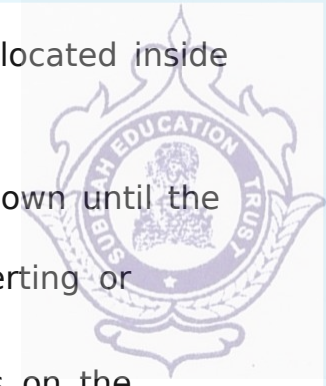

(b) Raise the measuring rod, tilt slightly and let it rest on the pin located inside the tester.

(c) Insert the tester on the levelled surface of concrete vertically down until the disc floats rests at the surface of the concrete. Do not rotate while inserting or removing the tester.

(d) After 60 seconds, lower the measuring rod slowly until it rests on the surface of the concrete that has entered the tube and read the K-Slump directly on the scale of the measuring rod.

(e) Raise the measuring rod again and let it rest on its pin.

(f) Remove the tester from the concrete vertically up and again lower the measuring

rod slowly till it touches the surface of the concrete retained in the tube and read

workability (W) directly on the scale of the measuring rod.

The K-slump apparatus is very simple, practical, and economical to use, both in the field and the laboratory. The K-slump tester can be used to measure slump in one minute in cylinders, pails, buckets, wheel-barrows, slabs or any other desired location where the fresh concrete is placed.

COMPACTING FACTOR TEST

The compacting factor test is designed primarily for use in the laboratory but it can also be used in the field. It is more precise and sensitive than the slump test and is particularly useful for concrete mixes of very low workability as are normally used when concrete is to be compacted by vibration. Such dry concrete are insensitive to slump test.

The degree of compaction, called the compacting factor is measured by the density ratio i.e., the ratio of the density actually achieved in the test to density of same concrete fully compacted. The sample of concrete to be tested is placed in the upper hopper up to the brim. The trap-door is opened so that the concrete

falls into the lower hopper. Then the trap-door of the lower hopper is opened and the concrete is allowed to fall into the cylinder. In the case of a dry-mix, it is likely that the concrete may not fall on opening the trap-door. In such a case, a slight poking by a rod may be required to set the concrete in motion. The excess concrete remaining above the top level of the cylinder is then cut off with the help of plane blades supplied with the apparatus. The outside of the cylinder is wiped clean. The concrete is filled up exactly upto the top level of the cylinder. It is weighed to the nearest 10 grams. This weight is known as —Weight of partially compacted concrete.

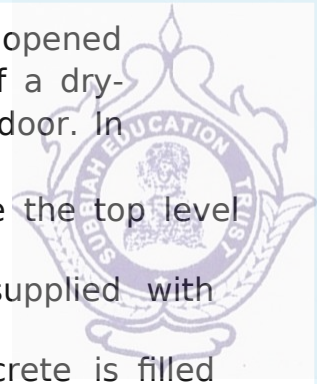

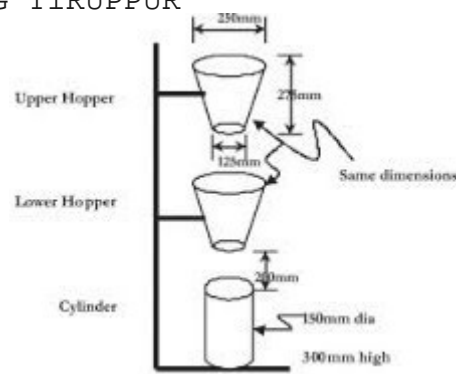

The cylinder is emptied and then refilled with the concrete from the same sample in layers approximately 5 cm deep. The layers are heavily rammed or preferably vibrated so as to obtain full compaction. The top surface of the fully compacted concrete is then carefully struck off level with the top of the cylinder and weighed to the nearest 10 gm. This weight is known as Weight of fully compacted concrete.

The compaction factor =
$$\frac{\text{Weight of partially compacted concrete}}{\text{Weight of fully compacted concrete}}$$

FLOW TEST

This is a laboratory test, which gives an indication of the quality of concrete with respect to consistency, cohesiveness and the proneness to segregation. In this test, a standard mass of concrete is subjected to jolting. The spread or the flow of the concrete is measured and this flow is related to workability.

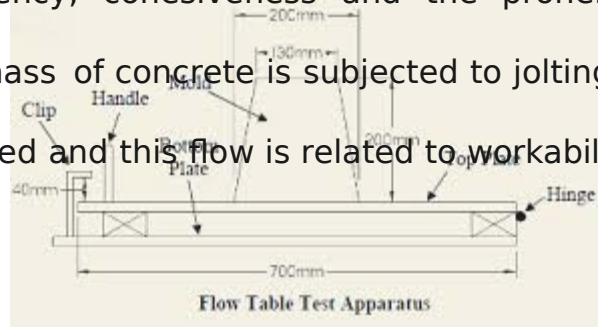

It can be seen that the apparatus consists of flow table, about 76 cm. in diameter over which concentric circles are marked. A mould made from smooth metal casting

in

the form of a frustum of a cone is used with the following internal dimensions.

The

base is 25 cm. in diameter, upper surface 17 cm. in diameter, and height of

the cone is 12 cm. The table top is cleaned of all gritty material and is

wetted. The mould is kept

on the centre of the table, firmly held and is filled in two layers. Each layer is rodded

25 times with a tamping rod 1.6 cm in diameter and 61 cm long rounded at the lower

tamping end. After the top layer is rodded evenly, the excess of concrete which has

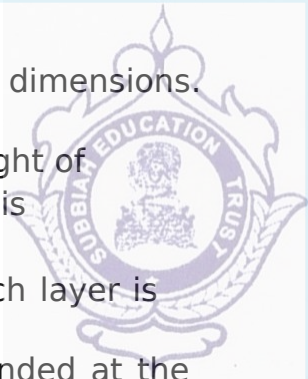

overflowed the mould is removed. The mould is lifted vertically upward and the concrete stands on its own without support. The table is then raised and dropped 12.5 mm 15 times in about 15 seconds. The diameter of the spread concrete is measured in about 6 directions to the nearest 5 mm and the average spread is noted. The flow of concrete is the percentage increase in the average diameter of the spread concrete over the base diameter of the mould

$$\text{Flow per cent} = \frac{\text{Spread diameter in cm} - 25}{25} \times 100$$

The value could range anything from 0 to 150 per cent. A close look at the pattern of spread of concrete can also give a good indication of the characteristics of concrete such as tendency for segregation.

VEE BEE CONSISTOMETER TEST

This is a good laboratory test to measure indirectly the workability of concrete. This test consists of a vibrating table, a metal pot, a sheet metal cone, a standard iron rod. Slump test as described earlier is performed, placing the slump cone inside the metal cylindrical pot of the consistometer. The glass disc attached to the swivel arm is turned and placed on the top of the concrete in the pot. The electrical vibrator is then switched on and simultaneously a stop watch started.

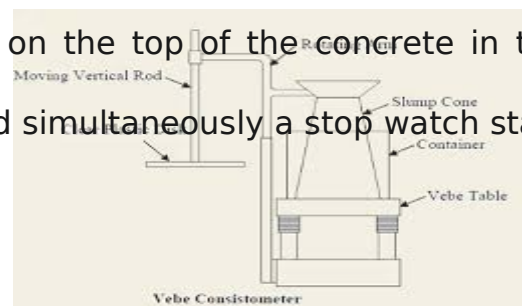

The vibration is continued till such a time as the conical shape of the concrete disappears and the concrete assumes a cylindrical shape. This can be judged by

observing the glass disc from the top for disappearance of transparency.

Immediately

when the concrete fully assumes a cylindrical shape, the stop watch is switched off.

The time required for the shape of concrete to change from slump cone shape to

cylindrical shape in seconds is known as Vee Bee Degree. This method is very suitable for very dry concrete whose slump value cannot be measured by Slump Test but the vibration is too vigorous for concrete with a slump greater than about 50 mm.

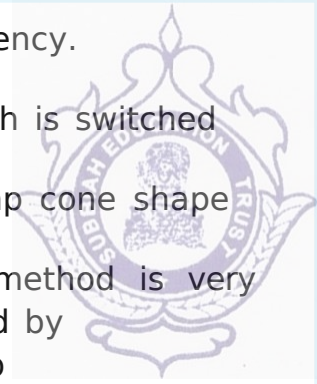

3. Explain segregation and Bleeding?

Segregation

Segregation can be defined as the separation of the constituent materials of concrete. A good concrete is one in which all the ingredients are properly distributed to make a homogeneous mixture. If a sample of concrete exhibits a tendency for separation of say, coarse aggregate from the rest of the ingredients, then, that sample is said to be showing the tendency for segregation. Such concrete is not only going to be weak; lack of homogeneity is also going to induce all undesirable properties in the hardened concrete.

A well made concrete, taking into consideration various parameters such as grading, size, shape and surface texture of aggregate with optimum quantity of waters makes a cohesive mix. Such concrete will not exhibit any tendency for segregation. The cohesive and fatty characteristics of matrix do not allow the aggregate to fall apart, at the same time, the matrix itself is sufficiently contained by the aggregate. Similarly, water also does not find it easy to move out freely from the rest of the ingredients.

The conditions favorable for segregation are, the badly proportioned mix where sufficient matrix is not there to bind and contain the aggregates. Insufficiently mixed concrete with excess water content shows a higher tendency for segregation. Dropping of concrete from heights as in the case of placing concrete in column concreting will result in segregation.

When concrete is discharged from a badly designed mixer, or from a mixer with worn out blades, concrete shows a tendency for segregation. Conveyance of concrete by conveyor belts, wheel barrow, long distance haul by dumper, long lift by skip and hoist are the other situations promoting segregation of concrete. Vibration of concrete is one of the important methods of compaction. It should be remembered that only comparatively dry mix should be vibrated. It too wet a mix is



excessively

vibrated, it is likely that the concrete gets segregated.

A cohesive mix would reduce the tendency for segregation. For this reason, use of certain workability agents and pozzolanic materials greatly help in reducing segregation. The use of air- entraining agent appreciably reduces segregation.

Segregation is difficult to measure quantitatively, but it can be easily observed at the time of concreting operation. The pattern of subsidence of concrete in slump test or the pattern of spread in the flow test gives a fair idea of the quality of concrete with respect to segregation.



Bleeding

Bleeding is sometimes referred as water gain. It is a particular form of segregation, in which some of the water from the concrete comes out to the surface of the concrete, being of the lowest specific gravity among all the ingredients of concrete. Bleeding is predominantly observed in a highly wet mix, badly proportioned and insufficiently mixed concrete. In thin members like roof slab or road slabs and when concrete is placed in sunny weather show excessive bleeding. Due to bleeding, water comes up and accumulates at the surface. Sometimes, along with this water, certain quantity of cement also comes to the surface. When the surface is worked up with the trowel and floats, the aggregate goes down and the cement and water come up to the top surface. This formation of cement paste at the surface is known as Laitance. Water while traversing from bottom to top, makes continuous channels. If the water cement ratio used is more than 0.7, the bleeding channels will remain continuous and unsegmented by the development of gel. This continuous bleeding channels are often responsible for causing permeability of the concrete structures.

While the mixing water is in the process of coming up, it may be intercepted by aggregates. The bleeding water is likely to accumulate below the aggregate. This accumulation of water creates water voids and reduces the bond between the aggregates and the paste. The above aspect is more pronounced in the case of flaky aggregate. Similarly, the water that accumulates below the reinforcing bars, particularly below the cranked bars, reduces the bond between the reinforcement and the concrete. The poor bond between the aggregate and the paste or the reinforcement and the paste due to bleeding can be remedied by revibration of concrete. The formation of laitance and the consequent bad effect can be reduced by delayed finishing operations.

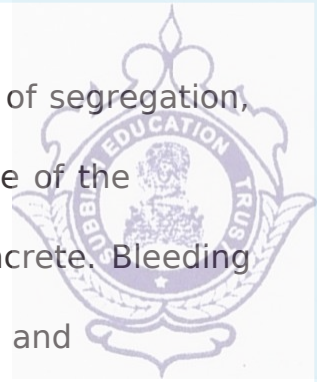

Bleeding rate increases with time up to about one hour or so and thereafter the rate decreases but continues more or less till the final setting time of cement. Bleeding is an inherent phenomenon in concrete. All the same, it can be reduced by proper proportioning and uniform and complete mixing. The bleeding is not completely harmful if the rate of evaporation of water from the surface is equal to the rate of bleeding.

Method of Test for Bleeding of Concrete

This method covers determination of relative quantity of mixing water that will bleed from a sample of freshly mixed concrete. A cylindrical container of approximately 0.01 m³ capacity, having an inside diameter of 250 mm and inside height of 280 mm is used. A tamping bar similar to the one used for slump test is used. A pipette for drawing off free water from the surface, a graduated jar of 100 cm³ capacity is required for test. A sample of freshly mixed concrete is obtained. The concrete is filled in 50 mm layer for a depth of 250 ± 3 mm (5 layers) and each layer is tamped by giving strokes,

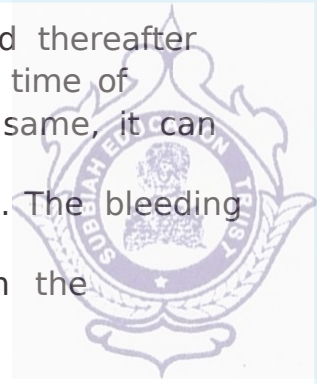

and the top surface is made smooth by trowelling.

The test specimen is weighed and the weight of the concrete is noted. Knowing the total water content in 1 m³ of concrete quantity of water in the cylindrical container is also calculated. The cylindrical container is kept in a level surface free from vibration at a temperature of 27°C ± 2°C. It is covered with a lid. Water accumulated at the top is drawn by means of pipette at 10 minutes interval for the first 40 minutes and at 30 minutes interval subsequently till bleeding ceases. To facilitate collection of bleeding water the container may be slightly tilted. All the bleeding water collected in a jar.



$$\text{Bleeding water percentage} = \frac{\text{Total quantity of bleeding water}}{\text{Total quantity of water in concrete}} \times 100$$

4. Explain the properties of fresh and hardened concrete?

PROPERTIES OF FRESH CONCRETE

The fresh concrete or plastic concrete is the initial stage of concrete period and it is counted from the mixing stage till it is transported, placed, compacted and finished in the position. The fresh concrete must satisfy the following requirements. Ideal Requirements of Fresh Concrete

i. Mixability

The mix should be able to produce a homogeneous and uniform fresh concrete from the constituent materials of each batch under the action of mixing forces.

ii. Stability

The mix should be stable meaning thereby it should not segregate during transporting and placing and also the tendency of the bleeding should be minimum.

iii. Mobility/Flowability

The mix should be mobile enough to surround all reinforcement without leaving any voids behind as well as to completely fill the formwork.

iv. Compactability

The mix should be amenable to proper and thorough minimum compaction into a

dense compact concrete under the existing facilities of compaction at site.

v. Finishability

It should be able to obtain a uniform and satisfying surface finish. PROPERTIES OF HARDENED CONCRETE

The concrete is a basic prime building material because of various properties being possessed during its hardened state which starts from the day it attains the full



designed strength to the end of its life. For hardened concrete, the various properties

which need consideration are as follows.

(A) STRENGTH

- a. Compressive strength
- b. Tensile strength
- c. Flexural strength
- d. Shear strength
- e. Bond strength

(B) Durability

(C) Impermeability

(D) Dimensional Changes

- (a) Elasticity
- (b) Shrinkage
- (c) Creep
- (d) Thermal expansion
- (e) Fatigue

(E) Fire Resistance

STRENGTH OF CONCRETE

The strength of concrete is the most important property as far as structural

design are concerned. Indirectly, it provides an overall idea of properties such as impermeability, durability, wear resistance etc) also. A strong concrete is more dense, compact, impermeable and resistant to weathering and chemical attacks.

Meaning thereby, the strength of concrete gives an overall idea of its quality. Strength of concrete is defined as the ability to resist force and for structural purposes, it is taken as the unit force required to cause rupture which may be caused by



Compressive Strength of Concrete

The compressive strength of concrete is considered the basic character of the concrete. Consequently, it is known as the **characteristic compressive strength of concrete (f_{ck})** which is defined as that value below which not more than five percent of test results are expected to fall based on IS: 456-2000. In this definition the test results are based on 150 mm cube cured in water under temp. of $27 \pm 2^\circ\text{C}$ for 28

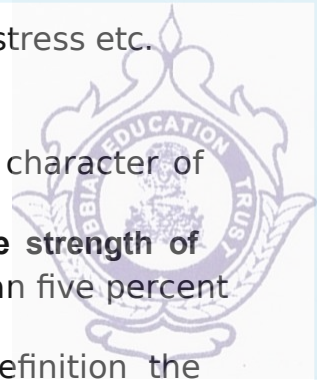

days and tested in the most saturated condition under direct compression.

Other strength viz, direct tensile stress, flexural stress, shear stress and bond stress also are directly proportional to the compressive stress. Higher is the compressive stress, higher is other stresses also. Not only stresses, other properties for example modulus of elasticity, abrasion and impact resistances, durability are also taken to be related to the compressive strength, hence, the compressive strength is an index of overall quality of concrete.



Factors Affecting Compressive Strength

Among the materials and mix variables, **water -cement ratio** is the most important parameter governing the compressive strength. Besides W/C ratio, following factors also affect the compressive strength.

- The characteristics of cement.
- The characteristics and properties of aggregates.
- The degree of compaction
- The efficiency of curing
- Age at the time of testing.
- Conditions of testing.

Water -Cement Ratio

The water -cement ratio, defined as the ratio of the mass of free water (i.e. excluding that absorbed by the aggregate) to that of cement in a mix, is the most important factor that controls the strength and many other properties of concrete. In practice, this ratio lies generally in the range of 0.35 to 0.65, although the purely chemical requirement (for the purpose of complete hydration of cement) is only about 0.25. The compressive strength of concrete at a given age and under normal temperature, depends primarily on w/c ratio; lower the w/c ratio, greater is the compressive strength and vice versa. This was first enunciated by Abrams as $S = \frac{K}{(w/c)^n}$ where S is the compressive strength, w/c is water -cement ratio of a fully

compacted

concrete mix, K_1 and K_2 are empirical constants.

In day-to-day practice, the constants K_1 and K_2 are not evaluated, instead the relationship between compressive strength and w/c ratio are adopted

which are supposed to be valid for a wide range of conditions. Effect of water

-
cement ratio on compressive strength at different ages. A reduction in the water

cement ratio generally results in an increased quality of concrete in terms of strength, density, impermeability, reduced shrinkage and creep etc.

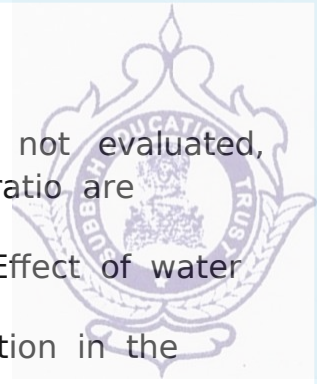

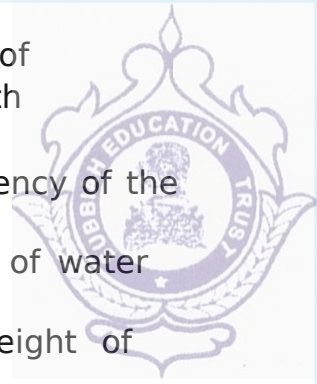

The probable reason, why lower w/c ratio gives higher strength of concrete may be found by considering the cement forms a paste with water and it is this paste that binds the different particles of aggregates. So thicker is the consistency of the paste, greater is its binding property. Another reason is that the quantity of water required for chemical combination is very small (about 25% of the weight of cement) compared with that required for workability and the excess water ultimately on evaporation leaves pores.

The greater is the excess of water, greater is loss of strength and water-tightness. The tensile strength and bond strength with steel do not decrease with increase in w/c ratio to the same extent as compressive strength does. Say with increase in w/c ratio from 0.5 to 0.6, the decrease in tensile strength and bond strength is 10% but decrease in compressive strength is about 25%.

Characteristics and properties of cement

The type of cement and fineness of cement affect the strength of concrete. With respect to Ordinary Portland cement (OPC), Rapid Hardening Portland Cement (RHPC) and Low Heat Portland Cement (LHPC) give higher and lower strength respectively. The rate of gain of strength depends entirely upon fineness of the cement. Finer cement increases the rate of hydration and hydrolysis which results in early development of strength though the ultimate strength is not affected.

Characteristics And Properties Of Aggregates

The strength of concrete is governed by

- strength of aggregate
- strength of mortar
- bond strength between mortar and aggregate

The strength of aggregate is normally greater than the strength of mortar and bond between mortar and aggregate. The strength of mortar depends upon w/c

ratio

whereas bond between mortar and aggregate depends upon the strength of mortar

and the size, shape, texture and grading of aggregate. Larger maximum size of

coarse aggregate gives lower compressive strength of concrete. The reasons behind

may be stated as follows. The larger maximum size aggregate gives lower surface

area for development of gel bond which is responsible for lower strength.

Aggregates of smaller size, angular aggregate and aggregate of rough surface

texture provides more surface area and more consumption of cement and hence more

bond strength. Bigger aggregate size causes a more heterogeneity in the concrete

and this prevents uniform distribution of load when stressed. For larger size aggregate

the transition zone becomes much weaker due to development of micro cracks

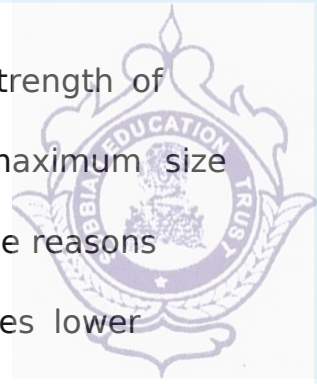

which result in lower compressive strength.

The degree of compaction

Higher is the compaction of freshly mixed concrete, more is the reduction of the voids and consequently greater is the compressive strength of concrete.

The efficiency of curing

Curing is the name given to procedures used for promoting the hydration of cement, and consist of a control of temperature and of the moisture movement from and into the concrete.

Hydration of cement takes place in capillaries filled with water.

By keeping concrete saturated, loss of water by evaporation from the capillaries is prevented and loss of water by self desiccation (due to the chemical reactions of hydration of cement) from outside.

Curing should be continued until the originally water filled space in the fresh cement paste has been filled by product of hydration to the desired extent. Curing temperature should be from 23° to 30°C (27°C average).

The curing must be adequate at favorable temperature for sufficient period which helps in attaining the maximum strength and other desirable properties. Age of Concrete The strength of concrete increases with age as the hydration of cement prolongs for a considerable time.

Conditions of Testing

After adequate curing, the concrete mould is tested in the moist saturated condition with surface wiped out under direct compression. The strength of concrete is influenced by moisture content at the time of testing, because moisture content in concrete provides lubrication effect and reduces the strength when compared with dry sample. Strength in dry sample = 1.10 to 1.20 times the strength of the saturated sample.

Strength of Prism Vs 150 mm Strength



The characteristic strength of concrete (f_{ck}) is based on 150 mm cube but if it is tested on the prism mould, the strength of prism specimen decreases with increase in height to the side ratio and stabilizes when this ratio is 5. Variation in Strength with Size of Cubes The characteristic strength of concrete is based on 150mm cube but the strength of concrete determined through the cube specimen varies with the size of cubes.

The strength of specimen increases with decrease in size and vice -versa as indicated in the Cube (150 mm) Strength Vs Cylinder (150 mm dia, 300 mm ht)

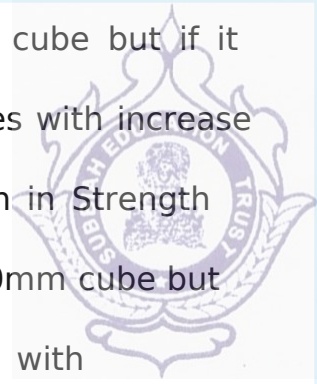

Strength If the concrete is tested on cylinder having 150 mm diameter and height

300 mm instead of 150 mm cube, the cube strength can be estimated as
Cylinder

$$\text{strength (fcu)} = 0.80 * \text{cube strength (fck)}$$

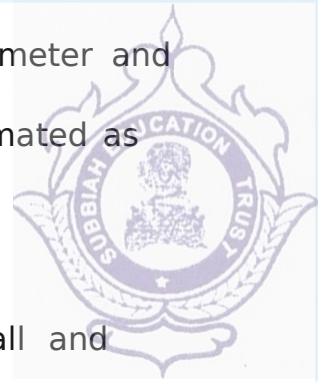

TENSILE STRENGTH

- Tensile strength of concrete under direct tension is very small and generally neglected in normal design practice. Although the value ranges from 8 to 12% of its

compressive strength. An average value 10% is the proper choice. The direct tension method suffers the problem like holding the specimen properly in the testing machine and the application of uniaxial tensile load not being free of eccentricity.

- The tensile strength can be calculated indirectly by loading a concrete cylinder to the compressive force along the two opposite ends (with its axis horizontal)

- Due to uniform tensile stress acting horizontally along the length of cylinder, the cylinder splits into two halves. The magnitude of this tensile stress (acting in a direction perpendicular to the line of action of applied compression) is given by

$$S = \frac{2P}{L \cdot D} \text{ where; } S = \text{Tensile stress in kg/cm}^2 \text{ } P = \text{load causing rupture in kg}$$

$$D = \text{Dia in cm (15 cm)}$$

$$L = \text{Length in cm (30 cm)}$$

- The indirect tensile stress is known as SPLITTING TENSILE STRENGTH.

FLEXURAL STRENGTH

The maximum tensile stress resisted by the plain concrete in flexure (bending) is called FLEXURAL STRENGTH (or MODULUS OF RUPTURE) expressed in N/mm^2 or kg/m^2 .

- The most common plain concrete subjected to flexure is a highway/runway pavement. The strength of pavement concrete is evaluated by means of bending test on beam specimen.

- The flexural strength (modulus of rupture) is determined by testing standard test specimens of 150 mm x 150 mm x 700 mm over a span of 600 mm or 100

mm x 100 mm x 500 mm over a span of 400 mm. under symmetrical two point loading

SHEAR STRENGTH

- Shear strength is the capacity of concrete to resist the sliding of the section over the adjacent section. A good amount of shear strength capacity is possessed by concrete depending upon the grade of concrete and percentage of tensile reinforcement in the section.
- It is difficult to obtain shear strength of concrete but I.S. code suggests the value for different grade of concrete.

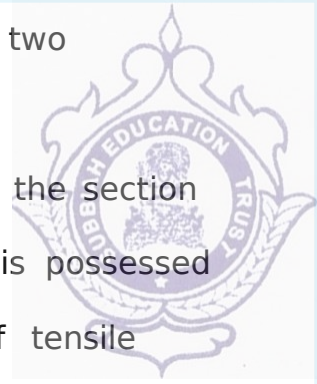



BOND STRENGTH

- Bond strength is the shear stress at the interface of reinforcement bar and surrounding concrete developed to resist any force that tries slippage of the reinforcement to its surrounding concrete. It is determined by PULL OUT TEST . The av. bond strength is 10% of compressive strength of concrete The bond strength depends upon grade of concrete, higher the grade, higher is the value of bond strength.

5) Explain in detail about the determination of Compressive and Flexural strength of concrete.

Compression Test

Compression test is most common test conducted on hardened concrete, partly because it is an easy test to perform, and partly because most of the desirable characteristic properties of concrete are qualitatively related to its compressive strength. The cube specimen is of the size 15 x 15 x 15 cm. If the largest nominal size of the aggregate does not exceed 20 mm, 10 cm size cubes may also be used as an alternative. Cylindrical test specimens have a length equal to twice the diameter. They are 15 cm in diameter and 30 cm long. Smaller test specimens may be used but a ratio of the diameter of the specimen to maximum size of aggregate, not less than 3 to 1 is maintained.

Failure of Compression Specimen

Due to load the cube or cylinder undergo lateral expansion owing to the Poisson's ratio effect. The steel platens do not undergo lateral expansion to the some extent that of concrete, with the result that steel restrains the expansion tendency of concrete in the lateral direction. This induces

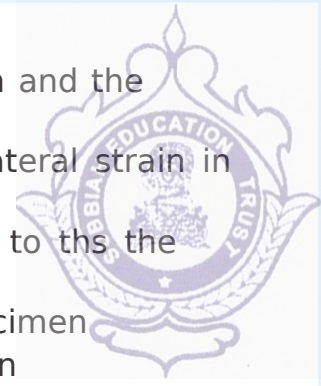

tangential force between the end surfaces of the concrete specimen and the adjacent steel platens of the testing machine. It has been found that the lateral strain in the steel platens is only 0.4 of the lateral strain in the concrete. Due to this the platen restrains the lateral expansion of the concrete in the parts of the specimen near its end. The degree of restraint exercised depends on the friction actually developed. When the friction is eliminated by applying grease, graphite or paraffin wax to the bearing surfaces the specimen exhibits a larger lateral expansion and eventually splits along its full length. With friction acting i.e., under normal conditions of test, the elements within the specimen is subjected to a shearing stress as well as compression. The magnitude of the shear stress decreases and the lateral expansion increases in distance from the platen. As a result of the restraint, in a specimen tested to destruction there is a relatively undamaged cone of height equal to $\sqrt{3/2} d$. But if the specimen is longer than about $1.7 d$, a part of it will be free from the restraining effect of the

platen. Specimens whose length is less than 1.5 d, show a considerably higher strength than those with a greater length.

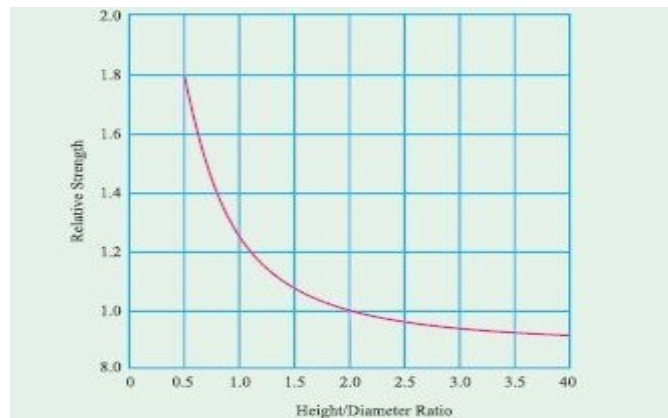

Effect of the Height/Diameter Ratio on Strength :

Normally, height of the cylinder — h — is made twice the diameter — d —, but sometimes, particularly, when the core is cut from the road pavements or airfield pavements or foundations concrete, it is not possible to keep the height/diameter ratio of 2:1. The diameter of the core depends upon the cutting tool, and the height of the core will depend upon the thickness of the concrete member. If the cut length of the core is too long. It can be trimmed to h/d ratio of 2 before testing. But with too short a core, it is necessary to estimate the strength of the same concrete, as if it had been determined on a specimen with h/d ratio equal to 2.

High strength concrete is less affected than the low strength concrete. Figure shows the influence of h/d ratio on the strength of cylinder for different strength levels.

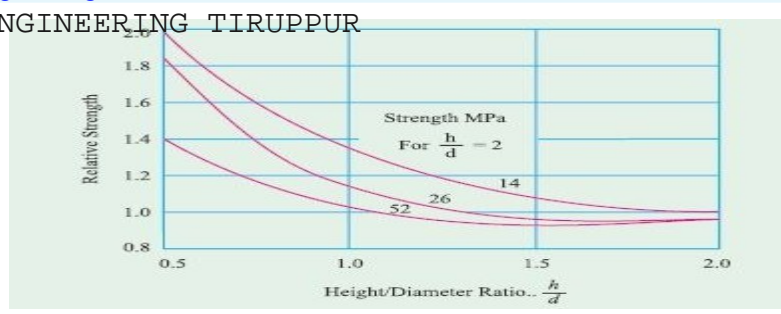

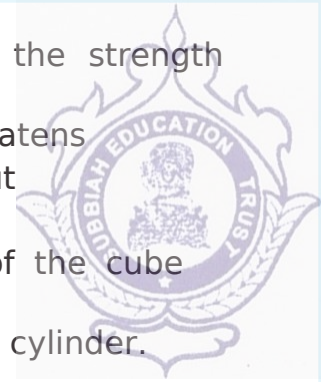

Figure shows the general pattern of influence of h/d ratio on the strength of cylinder. It is interesting to note that the restraining effect of the platens of the testing machine extends over the entire height of the cube but leaves unaffected a part of test cylinder because of greater height. It is, therefore, the strength of the cube made from identical concrete will be different from the strength of the cylinder. Normally

strength of the cylinder is taken as 0.8 times the strength of the cube, but experiments

have shown that there is no unique relationship between the strength of cube and

strength of cylinder. It was seen that the strength relation varies with the level of the

strength of concrete. For higher strength, the difference between the strength of cube and cylinder is becoming narrow. For 100 MPa concrete the ratio may become nearly 1.00.

The Flexural Strength of Concrete :

Concrete is relatively strong in compression and weak in tension. In reinforced concrete members, little dependence is placed on the tensile strength of

concrete since steel reinforcing bars are provided to resist all tensile forces. However, tensile stresses are likely to develop in concrete due to drying

shrinkage, rusting of steel reinforcement, temperature gradients and many other reasons.

Determination of Tensile Strength :

Direct measurement of tensile strength of concrete is difficult. Neither specimens nor

testing apparatus have been designed which assure uniform distribution of the pull applied to the concrete. While a number of investigations involving the direct measurement of tensile strength have been made, beam tests are found to be dependable to measure flexural strength property of concrete.

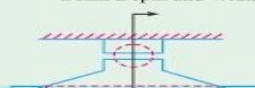
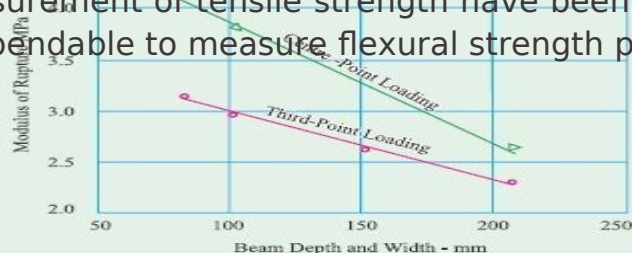

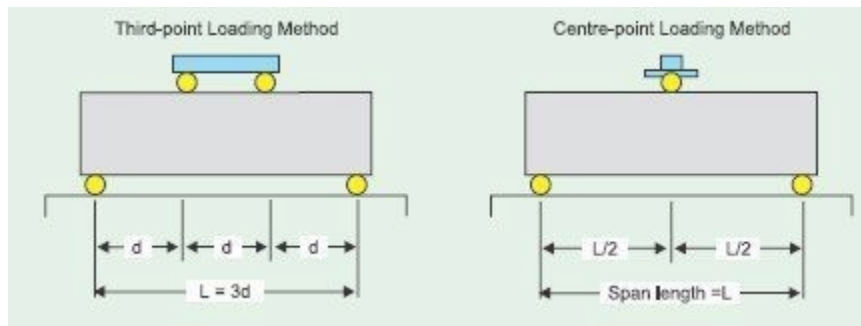

Procedure :

Test specimens are stored in water at a temperature of 24° to 30°C for 48 hours before testing. They are tested immediately on removal from the water

whilst they are still in a wet condition. The dimensions of each specimen should be

noted before testing. No preparation of the surfaces is required.

Placing the Specimen in the Testing Machine :

The bearing surfaces of the supporting and loading rollers are wiped clean, and any loose sand or other material removed from the surfaces of the specimen

where they are to make contact with the rollers. The specimen is then placed in the

machine in such a manner that the load is applied to the uppermost surface as cast in the mould, along two lines spaced 20.0 or 13.3 cm apart. The axis of the specimen is

carefully aligned with the axis of the loading device. No packing is used between the

bearing surfaces of the specimen and the rollers. The load is applied without shock and

increasing continuously at a rate such that the extreme fibre stress increases at

approximately 0.7 kg/sq cm/min that is, at a rate of loading of 400 kg/min for the

15.0 cm specimens and at a rate of 180 kg/min for the 10.0 cm specimens.

The load is increased until the specimen fails, and the maximum load applied to the specimen during the test is recorded. The appearance of the fractured

faces of concrete and any unusual features in the type of failure is noted.

The flexural strength of the specimen is expressed as the modulus of rupture f_b which if a' equals the distance between the line of fracture and the

nearest

support, measured on the centre line of the tensile side of the specimen, in cm, is

calculated to the nearest 0.05 MPa as follows:

$$f_b = \frac{P \times l}{b \times d^2}$$

When 'a' is greater than 20.0 cm for 15.0 cm specimen or greater than 13.3 cm for a 10.0 cm specimen, or

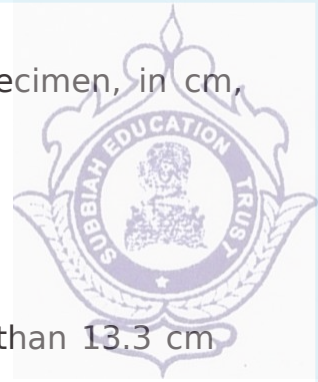

$$f_b = \frac{3p \times a}{b \times d^2}$$

when a' is less than 20.0 cm but greater than 17.0 cm for 15.0 cm specimen, or less than 13.3 cm but greater than 11.0 cm for a 10.0 cm specimen where

b = measured width in cm of the specimen,

d = measured depth in cm of the specimen at the point of failure,

l = length in cm of the span on which the specimen was supported, and p = maximum load in kg applied to the specimen.

If a' is less than 17.0 cm for a 15.0 cm specimen, or less than 11.0 cm for a 10.0 cm specimen, the results of the test be discarded.

As mentioned earlier, it is difficult to measure the tensile strength of concrete directly. Of late some methods have been used with the help of epoxy bonded end

pieces to facilitate direct pulling. Attempts have also been made to find out direct

tensile strength of concrete by making briquette of figure shape for direct pulling but

this method was presenting some difficulty with grip and introduction of secondary

stresses while being pulled. Whatever may be the methods adopted for finding out

the ultimate direct tensile strength, it is almost impossible to apply truly axial load.

There is always some eccentricity present. The stresses are changed due to eccentricity of loading.

These may introduce major error on the stresses developed regardless of specimen size and shape. The third problem is the stresses induced due to the grips. There is a tendency for the specimen to break near the ends. This problem is always

overcome by reducing the section of the central portion of the test specimen. The

method in which steel plates are glued with the epoxies to the ends of test specimen,

eliminates stresses due to gripping, but offers no solution for the eccentricity problem.

All direct tension test methods require expensive universal testing machine.



5. Explain in detail about the determination of Young's Modulus and Stress-

**strain curve
for concrete.**

When reinforced concrete is designed by elastic theory it is assumed that a perfect bond exists between concrete and steel. The stress in steel is m times the stress in concrete

where

m is the ratio between modulus of elasticity of steel and concrete, known as modular ratio.



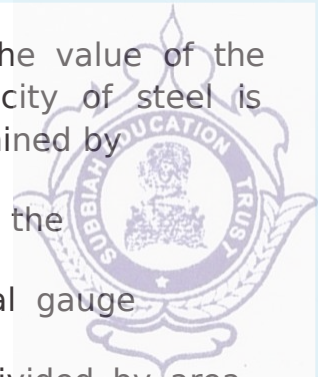

The accuracy of design will naturally be dependent upon the value of the modulus of elasticity of concrete, because the modulus of elasticity of steel is more or less a definite quantity. The modulus of elasticity is determined by

subjecting a cube or cylinder specimen to uniaxial compression and measuring the deformations

by means of dial gauges fixed between certain gauge length. Dial gauge reading

divided by gauge length will give the strain and load applied divided by area of

cross-section will give the stress. A series of readings are taken and the stress-strain

relationship is established. The modulus of elasticity can also be determined by

subjecting a concrete beam to bending and then using the formulae for deflection and

substituting other parameters.

The modulus of elasticity so found out from actual loading is called static modulus of elasticity. It is seen that even under short term loading concrete does not

behave as an elastic material. However, up to about 10-15% of the ultimate strength

of concrete, the stress-strain graph is not very much curved and hence can give more accurate value. For higher stresses the stress-strain relationship will be greatly curved and as such it will be inaccurate

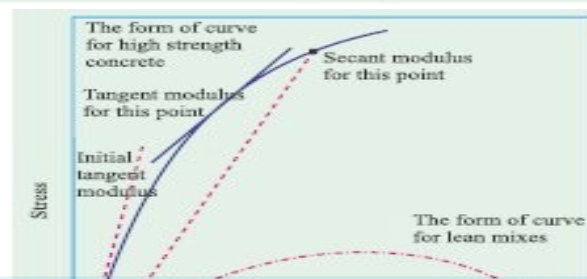
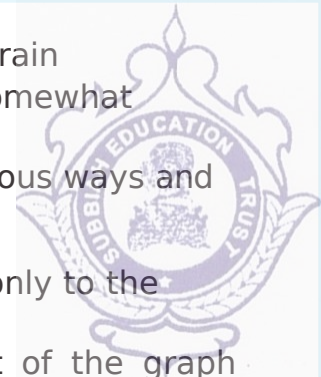



Figure shows stress strain relationship for various concrete mixes.



In view of the peculiar and complex behaviour of stress-strain relationship, the modulus of elasticity of concrete is defined in somewhat arbitrary manner. The modulus of elasticity of concrete is designated in various ways and they have been illustrated on the stress-strain curve in Fig.

The term Young's modulus of elasticity can strictly be applied only to the straight part of stress-strain curve. In the case of concrete, since no part of the graph is straight, the modulus of elasticity is found out with reference to the tangent drawn to the curve at the origin.

The modulus found from this tangent is referred as initial tangent modulus.

This gives satisfactory results only at low stress value. For higher stress value it gives a misleading picture. Tangent can also be drawn at any other point on the stress-strain curve. The modulus of elasticity calculated with reference to this tangent is then called tangent modulus. The tangent modulus also does not give a realistic value of modulus of elasticity for the stress level much above or much below the point at which the tangent is drawn. The value of modulus of elasticity will be satisfactory only for stress level in the vicinity of the point considered.

A line can be drawn connecting a specified point on the stress-strain curve to the origin of the curve. If the modulus of elasticity is calculated with reference to the slope of this line, the modulus of elasticity is referred as secant modulus. If the modulus of elasticity is found out with reference to the chord drawn between two specified points on the stress-strain curve then such value of the modulus of elasticity is known as chord modulus. The modulus of elasticity most commonly used in practice is secant modulus. There is no standard method of determining the secant modulus. Sometime it is measured at stresses ranging from 3 to 14 MPa and sometime the secant is drawn to point representing a stress

of 15, 25, 33, or 50 per cent of ultimate strength. Since the value of secant modulus decreases with increase in stress, the stress at which the secant modulus has been found out should always be stated.

Modulus of elasticity may be measured in tension, compression or shear. The modulus in tension is usually equal to the modulus in compression. It is interesting to

note that the stress-strain relationship of aggregate alone shows a fairly good straight line. Similarly, stress-strain relationship of cement paste alone also shows a fairly good straight line. But the stress-strain relationship of concrete which is

combination of aggregate and paste together shows a curved relationship.

Perhaps

this is due to the development of micro cracks at the interface of the aggregate and

paste. Because of the failure of bond at the interface increases at a faster rate than

that of the applied stress, the stress-strain curve continues to bend faster than

increase of stress. Figure shows the stress-strain relationship for cement paste,

aggregate and concrete.

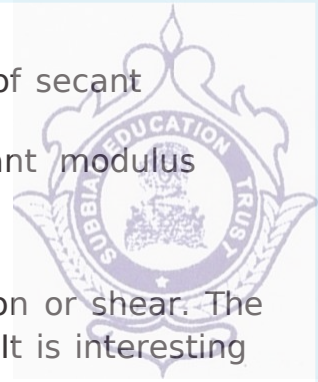



UNIT-V

SPECIAL CONCRETE

1. Define light weight concrete.

The concrete is said to be light weight concrete whose density is between 300 to 1850 kg/m³

2. Name some of the natural light weight aggregate

a. Pumice

[Diatomite](#)

[Scoria](#)

[Volcanic cinders](#)

[Saw dust](#)

[Rice husk](#)

[Name some of the artificial light weight aggregate](#)

[Brick bat](#)

[Foamed slag](#)

[Cinder, clinker](#)

[Bloated clay](#)

[Sintered fly ash](#)

[Exfoliated vermiculite](#)

Expanded perlite

4. Define Guniting or Shotcrete?

It is defined as a mortar conveyed through a hose and pneumatically projected at a high velocity on to a surface.

5. Define Polymer concrete?

Polymer concrete is part of group of concretes that use polymers to supplement or replace cement and uses polymer as a binder.

i. polymer impregnated concrete

ii. polymer cement concrete (pcc)

iii. polymer concrete



6. Define SIFCON?

Slurry Infiltrated Fibrous Reinforced Concrete (SIFCON) is a relatively new high performance and advanced material and can be considered as a special type of Steel Fiber Reinforced Concrete (SFRC). The technique of infiltrated layers of steel fibers with Portland cement based. Steel fibre bed is prepared and cement slurry is infiltrated. With this techniques macro-fibre content upto about 20% by volume can be achieved.

7. Define ferrocement?

Ferrocement is a relatively new material consisting of wire meshes and cement mortar. It consists of closely spaced wire meshes which are impregnated with rich cement mortar mix.

8. What is Geopolymer?

Geopolymer concrete is concrete based on an inorganic binder polymerized from Al-Si rich materials of geological or industrial origin, such as fly-ash. Geopolymer is used as the binder, instead of cement paste, to produce concrete.

9. Define Ready-mix concrete?

Concrete which is mixed in a stationary mixer in a central batching plant or in truck mixer and supplied in fresh condition to the purchaser either at site or into purchaser vehicle is called ready mix concrete.

10. Explain Fibre reinforced concrete

Fibre reinforced concrete is defined as the composite material consists of mixture of cement, mortar or concrete and discontinuous, discrete uniformly dispersed suitable fibres.

NATURAL FIBRES

Coconut fibre , Sugarcane, Straw, Jute fibres

SYNTHETIC FIBRES

Glass, carbon ,steel, polypropylene, nylon

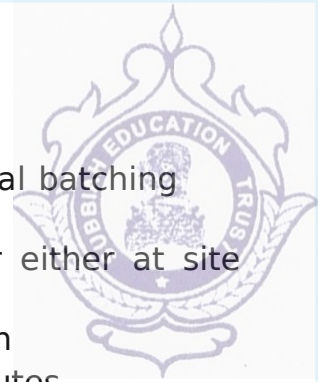

1. Explain the Ready Mix Concrete?

Concrete which is mixed in a stationary mixer in a central batching plant or in truck mixer and supplied in fresh condition to the purchaser either at site or into purchaser vehicle is called ready mix concrete. The age of fresh concrete is 2 to 3 hours and should be delivered within 30 to 60 minutes.

Concrete itself is a mixture of Portland cement, water and aggregates comprising sand and gravel or crushed stone. In traditional work sites, each of these materials is procured separately and mixed in specified proportions at site to make concrete.

Ready Mixed Concrete is bought and sold by volume - usually expressed in cubic meters. The first ready-mix factory was built in the 1930s, but the industry did not begin to expand significantly until the 1980s, and it has continued to grow since then.

The capacity is about 1.52 m^3 . The output of ready mix concrete is $30.58 \text{ m}^3/\text{hr}$ and can supply to a maximum of 1.33 m^3 for six times daily

Process:

A ready-mix concrete plant consists of silos that contain cement, sand, gravel and storage tanks of additives such as plasticizers, as well as a mixer to blend the components of concrete. These components are gravity fed into the preparation bin. The quality of concrete should be maintained.

The water dosage in particular must be very precise and the mixing itself must remain continuous and consistent. Finally, the concrete prepared in a batch plant is loaded into a mixer truck, also known as a transit mixer, which delivers it to the construction site. A concrete factory must be located within a radius of 20 to 30 km from the work site, depending on traffic conditions.

Storage
silos

Belt
conveyor

mixing
plant

→ transit mixer or

or machine or
batching unit



Components of RMC Plant:

- RMC Plant with Auxiliary or supporting equipment's.
- Transit mixer.
- Site equipment for handling concrete. (concrete pump)

Supporting equipment's:

- o cement silos
- o cement weight hopper
- o aggregate bins
- o conveyor

Properties:

- Good durability,
- High strength,
- Water tightness,

Resistance to abrasion.

Advantages

Speed in construction

Elimination of storage needs

Uniform and assured quantity of concrete

Reduction in wastage

RMC is eco-friendly

Documentation of mix design

Easy addition of admixtures

Disadvantages

The materials are batched at a central plant, and the mixing begins at that plant, so the travelling time from the plant to the site is critical over longer distances.

- Generation of additional road traffic. Furthermore, access roads and site access have to be able to carry the greater weight of the ready-mix truck plus load.
- Concrete's limited time span between mixing and going-off means that ready-mix should be placed within 90 minutes of batching at the plant. Modern admixtures can modify this time span precisely, however, the amount and type of admixture used, so the amount of admixture added to the mix is very important.

2. Explain the Light Weight Concrete?



Light

weight concrete is by large quantities air in
the aggregate in matrix or between the aggregate or by a
e, the in n e particles,
combination of processes. Aggregate that weight less than about 1000kg/m^3 are used.
on

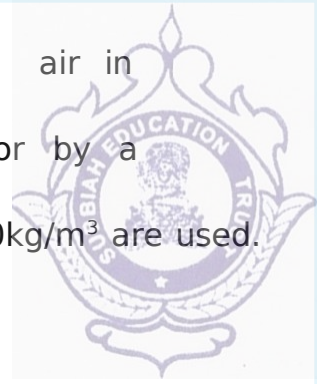

The light weight is due to the cellular structure or highly porous microstructure.

Natural light weight aggregates are made by processing igneous volcanic rocks such as pumice, scoria and tuff.

Synthetic light weight aggregates can be manufactured by thermal treatment from a variety of materials such as clay, shale, slate fly ash pallets, blast furnace slag.

Making:

The mixing procedure for light weight concrete is the same as for normal concrete and

is produced in the same type of mixer or mixing plant. In first stage, the mortar is

mixed i.e. cement, sand, admixtures, and about two-thirds of the water.

In the second stage, the coarse aggregate is added with the rest of the water and final

mixing is done. At times, light weight dry fines cause the material to form balls in the

mixer. It can be avoided if less water is added at the start and then the amount is

increased gradually. The size of the aggregate should be less than 8 or 10 mm.

Classification of light weight concretes:

i. By using porous light weight aggregate of low apparent specific gravity, i.e. lower

than 2.6. This type of concrete is known as light weight aggregate concrete.

ii. By introducing large voids within the concrete or mortar mass; these voids

should be clearly distinguished from the extremely fine voids produced by air entrainment. This type of concrete is variously known as aerated, cellular, foamed or gas concrete.

iii. By omitting the fine aggregate from the mix so that large amount of

interstitial voids is present; normal weight coarse aggregate is generally used. This

concrete is known as no-fine concrete.

Properties:

- Low compressive strength
- High water absorption and moisture content.

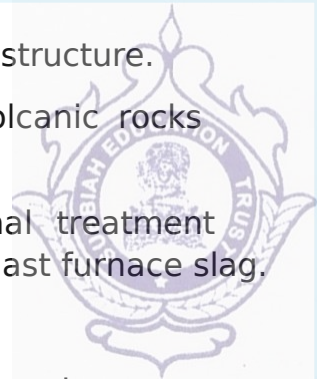

- High creep and shrinkage.
- Good thermal insulation due to air filled voids.
- Low thermal expansion.

Advantages

- o Rapid and relatively simple construction.
- o Economical in terms of transportation as well reduction in man power





- o Most of the light weight concrete have better nailing and sawing properties.
- o Significant reduction of overall weight and results in saving structural frames,
footings and piles

Disadvantages:

- ✚ Inability to provide high compressive strength ✚ Less density
- ✚ Very sensitive to moisture content
- ✚ Mixing time is longer than conventional concrete to obtain proper mixing.

3.Explain polymer concrete?

Polymer concrete is part of group of concretes that use polymers to supplement or replace cement and uses polymer as a binder.

Process:

The main technique in producing PC is to minimize void volume in the aggregate mass so as to reduce the quantity of polymer needed for binding the aggregates. This is achieved by properly grading and mixing the aggregates to attain the maximum density and minimum void volume.

The graded aggregates are prepacked and vibrated in a mould. Monomer is then diffused up through the aggregates and polymerization is initiated by radiation or chemical means. A silane coupling agent is added to the monomer to improve the bond strength between polymer and the aggregate. In polyester resins are used no polymerization is required. Polymer concrete can develop compressive strengths of the order of 140 MPa (20,000 psi) within hours or even minutes.

Such polymer concretes tend to be brittle and it is reported that dispersion of fibre reinforcement would improve the toughness and tensile strength of the material. The use of fibrous polyester concrete in the compressive region of reinforced concrete beams provides a high strength, ductile concrete at reasonable cost.

The types include polymer-impregnated concrete, polymer concrete, and

Properties:

- High tensile, flexural, and compressive strengths





- Good adhesion to most surfaces
- Good long-term durability with respect to freeze and thaw cycles
- Low permeability to water and aggressive solutions
- Good chemical resistance
- Good resistance against corrosion

Advantages:

- Rapid curing at ambient temperature.
- Lighter weight (only somewhat less dense than traditional concrete, depending on the resin content of the mix)
- Mines, tunnels, and highways.
- Pump manufacturing and chemical processing.
- Industries

Disadvantages

- More expensive
- The monomers can be volatile, combustible and toxic.
- Initiators which are used as catalyst are combustible and harmful to human skin

POLYMER IMPREGNATED CONCRETE

PIC is a hardened Portland cement concrete that has been impregnated with a monomer (low viscosity liquid organic material) and subsequently polymerized in situ. In this case the cement concrete is cast and cured in the conventional manner. After the concrete product gets hardened and dried, air from the voids is removed under partial vacuum and low viscosity monomer (styrene, vinyl chloride) is diffused through the pores of the concrete.

The concrete product is then finally subjected to polymerization by radiation or by heat treatment thereby converting the monomer filled in the voids into solid plastic.

Application:

- o precast slabs for bridge decks,
- o roads,
- o marine structures

o food processing buildings

1. POLYMER CEMENT CONCRETE(PCC)

PCC is produced by incorporating an emulsion of a polymer or a monomer in



ordinary Portland cement concrete. The ingredients comprising cement, aggregate and monomer are mixed with water and monomer in the concrete mix in the concrete is polymerized after placing concrete in position. The resultant concrete has improved :

- Strength,
- Adhesion
- Chemical resistance
- Impact and abrasion resistance
- Increased impermeability
- Reduced absorption

Application:

- o Marine Works

3. POLYMER CONCRETE

In polymer concrete polymer /monomer is used to act as binder in place of cement. The monomer and aggregate are mixed together and the monomer is polymerized after placement of concrete in position. It is imperative to pre-heat the coarse and fine aggregates while mixing monomer.

Application :

- Irrigation Works

4. Explain Fibre reinforced concrete?

Fibre reinforced concrete is defined as the composite material consists of mixture of cement, mortar or concrete and discontinuous, discrete uniformly dispersed suitable fibres.

- Plain cement concrete, due to its low tensile strength and impact resistance is considered to be a brittle material.
- However, marked improvement in these properties can be brought about by the addition of small diameter, short length, and randomly distributed fibres.
- The fibres can be imagined as an aggregate with an extreme deviation in shape from the rounded smooth aggregate. The fibres interlock and

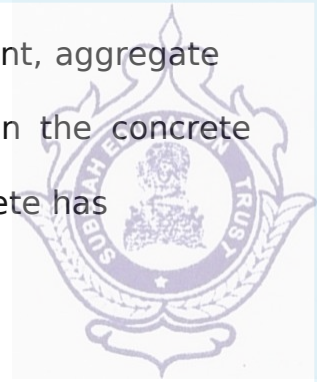

entangle

around aggregate particles and considerably reduce the workability, while the mix

becomes more cohesive and less prone to segregation.

- The fibres suitable for reinforcing the concrete have been produced from steel, glass and organic polymers.

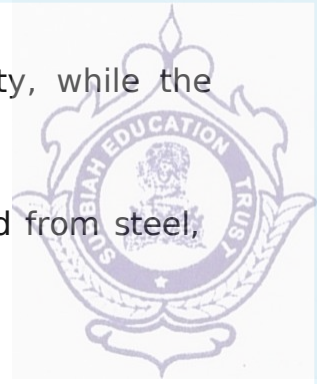

The major factors affecting the characteristics of fibre reinforced concrete are:

- water cement ratio;
- size of coarse aggregate
- mixing
- Percentage of fibres;
- Aspect ratio
- Diameter and length of fibres



The location and extent of cracking under load will depend upon the orientation

and number of fibres in the cross section. The fibre stress strain the shrinkage and

creep movements of unreinforced matrix. However fibres have been found to be more effective in controlling compression creep than tensile creep of unreinforced matrix.

Properties:

- Increased tensile and bending strength
- Improved ductility and resistance to cracking
- High impact strength and toughness
- Spalling resistance
- High energy absorption capacity

Application:

- o Hydraulic structures
- o Airfield and highway pavement
- o Bridge decks
- o Tunnel lining
- o Heavy duty floors

Disadvantage:

🚧 The main **disadvantage** associated with the fiber reinforced concrete is Fabrication. The process of incorporating fibers into the cement matrix is labor intensive.

- 🚧 Costlier than the production of the plain concrete.



Natural fibres

Coconut fibre

Sugarcane

Straw

Jute fibres

synthetic fibres

glass carbon

steel

nylon

polypropylene

SYNTHETIC FIBRES:

Steel fibre reinforced concrete

This type of concrete is formed by adding steel fibres in the ingredients of concrete. Round steel fibres are commonly used. The typical diameter lies in the range of .25 to .75 mm, by addition of 2 to 3 percent of fibre (by volume).

It is possible to achieve two or three times increase in the flexural strength of concrete and substantial increase in explosion resistance, crack resistance etc.

Application:

Construction of pavement

Bridge decks,

Pressure vessels ,

- o Tunnel lining

Glass fibre reinforced concrete:

Glass fibres are made up from 200 to 400 individual filaments which are highly bonded to make up a strand. These strands can be chopped into various lengths or combined into make cloth, mat or tape. The process of manufacture of

glass-fibre cement products may involve spraying, premixing or incorporation of continuous rovings. It has been observed that addition of 10% of glass fibres by

volume brings almost two folds increase in tensile strength and substantial increase in impact resistance of concrete.

Application:

- o Used in sewer lining
- o Roofing elements, swimming pool, tanks etc.
- o Polypropylene and nylon fibres.
- o Increase the impact strength.
- o Possess very high tensile strength

**Asbestos:**

- It is a mineral fibre
- Tensile strength varies between 560 and 980 N/mm².

Carbon fibres:

- Possess a tensile strength of 2110 to 2815 N/mm².
- Used in cladding, panels, shells

NATURAL FIBRES:**Coconut fibre as reinforcement**

Natural reinforcing materials can be obtained at low cost and low levels of energy using local manpower and technology. Utilization of natural fibres as a form

of concrete enhancement is of Particular interest to less developed regions

where conventional construction materials are not readily available or are too

expensive. Coconut and sisal-fibre reinforced concrete have been used for making

roof tiles, corrugated sheets, pipes, silos and tanks. The dry cement and aggregates

were mixed for two minutes by hand in a 0.1m³ laboratory mixer pan.

The mixing continued for further few minutes while about 80% of the water was added. The mixing was continued for another few minutes and the fibres were fed continuously to the concrete for a period of 2-3 min while stirring.

Finally, the remaining water along with super-plasticizer was added and the

mixing was continued for an additional two minutes. This ensured a complete

distribution of fibres throughout the concrete mix. For each mix, a total of six

cylinders with dimension of 100×200mm and three cubes of 100mm were cast.

5. Explain**(i) High strength concrete****(ii) High performance concrete****(iii) Geo polymer concrete****(iv) Ferro cement****High strength concrete**

The manufacture of high strength concrete will

grow to find its due place in concrete

construction for all the obvious benefits. In the modern batching plants high strength

concrete is produced in a mechanical manner. Of course, one has to take care about mix proportioning, shape of aggregates, use of supplementary cementitious materials,

silica fume and superplasticizers. With the modern equipments, understanding of the

role of the constituent materials, production of high strength concrete has become a

routine matter. There are special methods of making high strength concrete. They are given below.

(a) Seeding

(b) Revibration

(c) High speed slurry mixing;

(d) Use of admixtures

(e) Inhibition of cracks

(f) Sulphur impregnation

(g) Use of cementitious aggregates.

Seeding:

This involves adding a small percentage of finely ground, fully hydrated Portland cement to the fresh concrete mix. The mechanism by which this is

supposed to aid strength development is difficult to explain. This method may not hold

much

promise.

Revibration:

Concrete undergoes plastic shrinkage.

Mixing water creates continuous

capillary channels, bleeding, and water accumulates at some selected places. All these

reduce the strength of concrete. Controlled revibration removes all these defects



increases the strength of concrete.

High Speed slurry mixing:

This process involves the advance preparation of cement- water mixture which is then blended with aggregate to produce concrete. Higher compressive strength obtained is attributed to more efficient hydration of cement particles and water achieved in the vigorous blending of cement paste.





Use of Admixtures:

Use of water reducing agent are known to produce increased compressive strengths.

Inhibition of cracks:

Concrete fails by the formation and propagation of cracks. If the propagation of cracks is inhibited, the strength will be higher. Replacement of 2- 3% of fine aggregate by polythene or polystyrene —lenticules □ 0.025 mm thick and 3 to 4 mm in diameter results in higher strength. They appear to act as crack arresters without necessitating extra water for workability. Concrete cubes made in this way have yielded strength upto 105 MPa.

Sulphur Impregnation:

Satisfactory high strength concrete have been produced by impregnating low strength porous concrete by sulphur. The process consists of moist curing the fresh concrete specimens for 24 hours, drying them at 120°C for 24 hours, immersing the specimen in molten sulphur under vacuum for 2 hours and then releasing the vacuum and soaking them for an additional ½ hour for further infiltration of sulphur. The sulphur-infiltrated concrete has given strength upto 58 MPa.

Use of Cementitious aggregates:

It has been found that use of cementitious aggregates has yielded high strength. Cement found is kind of clinker. This glassy clinker when finely ground results in a kind of cement. When coarsely crushed, it makes a kind of aggregate known as ALAG. Using Alag as aggregate, strength upto 125 MPa has been obtained with water/cement ratio 0.32.

High performance concrete:

High Performance Concrete (HPC) is a specialized series of concretes designed to provide several benefits in the construction of concrete structures.

High

performance concrete possess high level of all characteristics of concrete, strength,

durability, all service life for durability of concrete. Conventional concrete designed on

the basis of compressive strength does not meet any functional requirements such as

impermeability, resistance to frost, thermal cracking etc. While high strength concrete

aims at enhancing strength. The term high performance concrete is used to refer

concrete of required performance for the majority of construction applications.

Making:

The mixing sequence of high performance concrete is as follows. Loading of the aggregates and water, addition of the air entraining agent and mixing to develop a

satisfactory air bubble system and stabilizing it. Mixing of cement. Addition of super

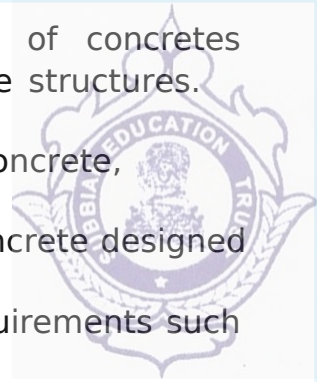



Properties:

- High workability.
- High durability
- Resistance to chemical attack.
- High strength
- High modulus of elasticity

Advantage:

- o ease of placement and consolidation without affecting strength
- o long-term mechanical properties
- o early high strength
- o toughness
- o volume stability
- o bridge decks, pavements and paving structures
- o longer life in severe environments

Disadvantage:

Highly expensive

Proportion of admixtures should be accurate otherwise the properties get changed.

GEPOLYMER CONCRETE :

Geopolymer concrete is a concrete based on inorganic binder polymerized from Al-Si rich materials of geological or industrial origin, such as fly-ash. Geopolymer is used as binder instead of cement paste, to produce concrete. The geopolymer paste binds the loose coarse aggregate fines together for geopolymer concrete. The manufacture of geopolymer concrete is carried out using the usual concrete technology methods.

As in the Portland cement concrete, the aggregates occupy the largest

volume,

that is approximately to by mass, geopolym concrete. The silicon
, 75 80% in er e. e
and the aluminum in the fly are activated combination sodium hydroxide
ash by a of m
and sodium silicate solution to the geopolym paste that binds the
m e s form e t s
aggregat and other unreacted materials.
es d

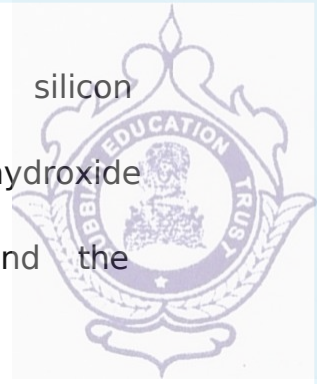

PROCESS:**Materials**

The materials needed to manufacture the geopolymer concrete are the same as

those for making Portland cement concrete, except for the Portland cement.

Low

calcium (class F) dry fly ash obtained from a local power station was used as the

source material. For the alkaline activator, a combination of sodium hydroxide solution and sodium silicate solution was used.

The sodium hydroxide solution was prepared by dissolving the sodium hydroxide solids, either in the form of pellets or flakes, in water. Extra water and

Naphthalene Sulfonate-based superplasticizer were also added to improve the

workability of the fresh fly ash-based geopolymer concrete. The sodium silicate

solution used contained $\text{Na}_2\text{O}=14.7\%$, $\text{SiO}_2=29.4\%$ and 55.9% water, by mass. All the liquids were mixed together before adding to the solids.

Mixing and Compacting

The aggregates in saturated surface dry condition and the dry fly ash were mixed in a pan mixer for 3-4 minutes. At the end of this mixing, the liquid

component of the geopolymer concrete mixture, i.e. the combination of the

alkaline solution, the superplasticiser and the extra water, was added to the solids, and the mixing continued for a specified period of time. In this study, the wet mixing

period was designated as the 'mixing time'.

The fresh concrete had a stiff consistency and was glossy in appearance. The fresh concrete was then cast in moulds. Compaction was performed using the usual

practice, either by applying strokes or using vibration or a combination of both.

After

casting, the concrete samples were cured at an elevated temperature for a specified

period of time.

Curing was carried out at a

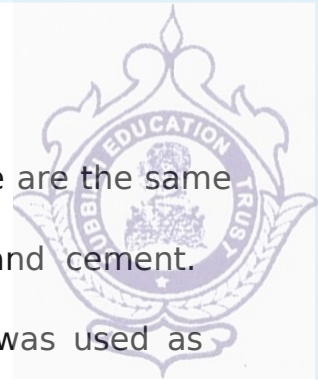

specimens either in an oven
at room temperature,
or at elevated

(dry curing) or in a steam chamber. At the end of the curing period, the test specimens were left in the mold for about six hours. The samples were then removed from the molds, and left to air dry in the room temperature before testing at a specified age

ENGINEERING PROPERTIES

- Compressive strengths ranging from 20-30MPa to 80-100MPa Ref. 1.
- Flexural strengths typically 2-3MPa higher than for OPC concrete at the same compressive strength
- Hardening in 5-7 days vs. 28 days for OPC concrete at ambient temperature.

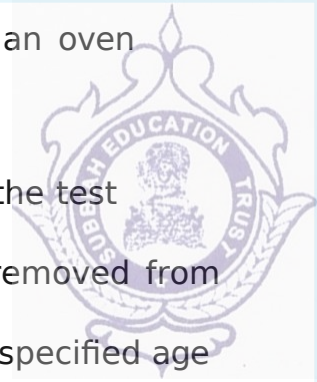

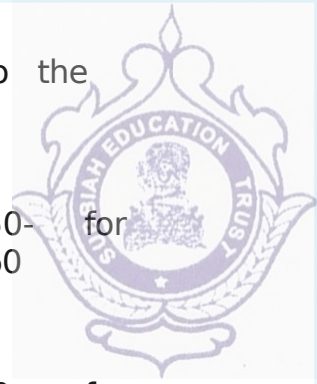

- Does not generate any heat of hydration during curing due to the polymerization nature of its chemistry.
- Low specific creep: typ 25-30 microstrains at 40% load vs 50-60 for OPC concrete.
- Low drying shrinkage: typ 100-150 microstrains @ 1 yr. vs 500-800 for OPC concrete.
- Excellent resistance to freeze-thaw cycles
- Adhesion to fresh and old concrete substrates, steel, glass, ceramics.
- Inherent protection of steel reinforcing due to low chloride diffusion rates.

SUPERIOR DURABILITY :

1) High level of resistance to a range of acids and salt solutions

- Na₂SO₄, MgSO₄, NaCl, Sulfuric Acid, Hydrochloric Acid
- Resistant to seawater corrosion

2) Not subject to deleterious alkali-aggregate reactions.

3) Impervious to water.

4) Fire resistance

□. No water molecules present in the geopolymer structure hence does not spall at high temperatures, unlike OPC concrete.

5) Does not burn or release toxic fumes, unlike organic polymers.

APPLICATIONS:

- ✚ metro/railroad systems, ✚ highways, bridges,
- ✚ marine infrastructure, ✚ dams, canal linings,
- ✚ water and sewage



ADVANTAGES:

- geopolymer concrete has significantly higher resistance to acid than ordinary concrete
- 80% reduction in CO₂ footprint comparing to OPC, opportunity to obtain tradable CO₂ certificates.
- Can be used in a wide range of ready-mix, pre-cast, and pre-stressed/pre-cast applications
 - Excellent fire and heat resistance. It has the ability to remain stable in temperatures of more than 1200 ° C

**DISADVANTAGES**

- o Activator is necessary to start the geopolymerisation process.
- o Due to the dangers of handling chemicals and the liability issues that ensue, geopolymer concrete is generally sold as a pre-cast or pre-mixed material

FERROCEMENT CONCRETE :

It is well known that conventional reinforced concrete members are too heavy, brittle, cannot be satisfactorily repaired if damaged, develop cracks and reinforcements are liable to be corroded. The above disadvantages of normal concrete make it inefficient for certain types of work.

Ferrocement is a relatively new material consisting of wire meshes and cement mortar. It consists of closely spaced wire meshes which are impregnated with rich cement mortar mix. The wire mesh is usually of 0.5 to 1.0 mm dia wire at 5 mm to 10 mm spacing and cement mortar is of cement sand ratio of 1 : 2 or 1 : 3 with water/cement ratio of 0.4 to 0.45. The ferrocement elements are usually of the order of 2 to 3 cm. in thickness with 2 to 3 mm external cover to the reinforcement.

The steel content varies between 300 kg to 500 kg per cubic meter of mortar. The basic idea behind this material is that concrete can undergo large strains in the neighborhood of the reinforcement and the magnitude of strains depends on the distribution and subdivision of reinforcement throughout of the mass of concrete.

6. Describe in detail about Shotcrete and its advantages.

Shotcrete or Guniting can be defined as mortar conveyed through a hose and pneumatically projected at a high velocity on to a surface. Recently the method has been further developed by the introduction of small sized coarse aggregate into the mix deposited to obtain considerably greater thickness in one operation and also to make the process economical by reducing the cement content. Normally fresh material with zero slump can support itself without sagging or peeling

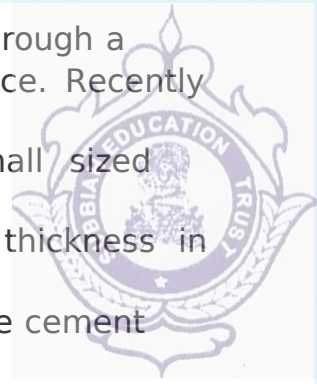

off. The force of the jet impacting on the surface compact the material. Sometimes use of set accelerators to assist overhead placing is practised. The newly developed —Redi-set cement can also be used for shotcreting process.



There is not much difference between guniting and shotcreting. Guniting was first used in the early 1900 and this process is mostly used for pneumatical application of mortar of less thickness, whereas shotcrete is a recent development on the similar principle of guniting for achieving greater thickness with small coarse aggregates.

There are two different processes in use, namely the Wet-mix process and the dry- Mix process. The dry mix process is more successful and generally used.

Dry-mix Process

The dry mix process consists of a number of stages and calls for some specialized plant. A typical small plant set-up is shown in Fig. The stages involved in the dry mix process is given below:

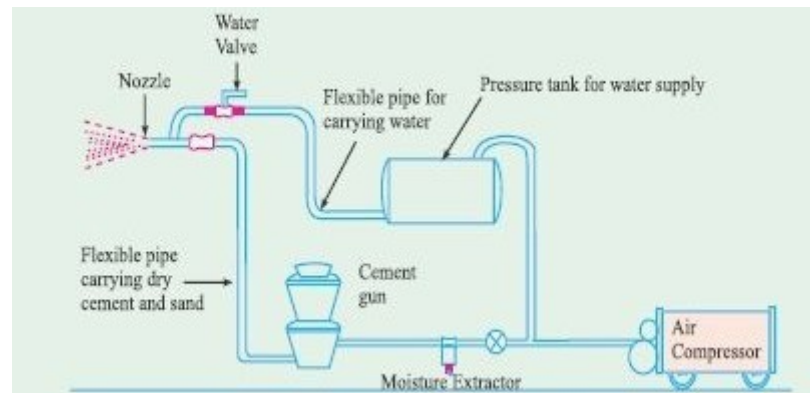

Cement and sand are thoroughly mixed.

- The cement/sand mixture is fed into a special air-pressurised mechanical feeder termed as ‘gun’.
- The mixture is metered into the delivery hose by a feed wheel or distributor within the gun.
- This material is carried by compressed air through the delivery hose to a special nozzle.

- The nozzle is fitted inside with a perforated manifold through which water is sprayed under pressure and intimately mixed with the sand/cement jet.
- The wet mortar is jetted from the nozzle at high velocity onto the surface to be gunited.

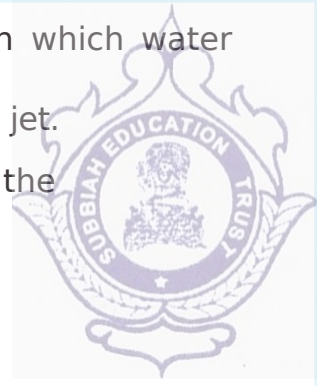

The Wet-mix Process

In the wet-mix process the concrete is mixed with water as for ordinary concrete before conveying through the delivery pipe line to the nozzle, at which point it is jetted by compressed air, onto the work in the same way, as that of dry mix process. The wet-mix process has been generally discarded in favour of the dry-mix process, owing to the greater success of the latter.

The dry-mix methods makes use of high velocity or low velocity system. The high velocity gunite is produced by using a small nozzle and a high air pressure to produce a high nozzle velocity of about 90 to 120 metres per second. This results in exceptional good compaction. The lower velocity gunite is produced using large diameter hose for large output. The compaction will not be very high.

Advantages of Wet and Dry Process

Although it is possible to obtain more accurate control of the water/cement ratio with the wet process the fact that this ratio can be kept very low with the dry process largely overcomes the objection of the lack of accurate control. The difficulty of pumping light-weight aggregate concrete makes the dry process more suitable when this type of aggregate is used. The dry process on the other hand, is very sensitive to the water content of the sand, too wet a sand causes difficulties through blockade of the delivery pipeline, a difficulty which does not arise with the wet process. The lower water/cement ratio obtained with the dry process probably accounts for the lesser creep and greater durability of concrete produced in this way compared with concrete deposited by the wet process, but air-entraining agents can be use to improve the durability of concrete deposited by the latter means.

Admixtures generally can be used more easily with the wet process except for accelerators. Pockets of lean mix and of rebound can occur with the dry

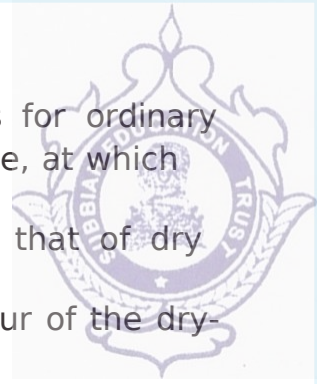

process. It is necessary for the nozzleman to have an area where he can dump unsatisfactory shotcrete obtained when he is adjusting the water supply or when he is having trouble with the equipment. These troubles and the dust hazard are less with

the wet process, but wet process does not normally give such a dense concrete as the dry process. Work can be continued in more windy weather with the wet process than with the dry process, Owing to the high capacities obtainable with concrete pumps, a higher rate of laying of concrete can probably be achieved in the wet process than with the dry process.

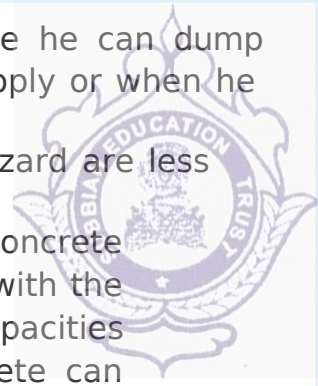

Reg. No.

--	--	--	--	--	--	--	--	--	--	--	--	--	--	--	--	--	--	--	--



Question Paper Code : 57137

B.E./B.Tech. DEGREE EXAMINATION, MAY/JUNE 2016

Sixth Semester

Civil Engineering

CE 6002 – CONCRETE TECHNOLOGY

(Regulations 2013)

Time : Three Hours

Maximum : 100 Marks

**Mix design tables and charts are permitted.
Answer ALL questions.**

PART – A (10 × 2 = 20 Marks)

1. Name the major compounds of ordinary Portland cement and mention the approximate percentage of each.
2. What should be the qualities of water to be used in concrete making ?
3. What is meant by pozzolanic action ?
4. State the advantages and disadvantages of using super plasticizers in concrete ?
5. What are the objectives of a concrete mix design ?
6. Distinguish between Design mix and Nominal mix.
7. Why does a concrete cylinder fail at a lower stress than a concrete cube ?
8. What are the effect of water cement ratio on concrete strength and durability ?
9. Define : High Performance Concrete.
10. What is polymer concrete ? State its advantages.

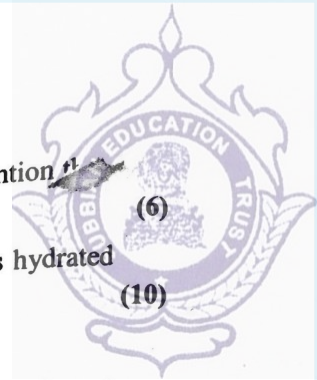

PART - B (5 × 16 = 80 Marks)

11. (a) (i) What are the raw materials for the manufacture of cement? Mention functions in the properties of cement. (6)
- (ii) Discuss the role of various major compounds of cement and its hydrated products in the properties of cement. (10)

OR

- (b) (i) What are the requirements of physical and mechanical properties of good coarse aggregate for concreting? (6)
- (ii) Explain any two methods of finding the abrasion value of a coarse aggregate. (10)
12. (a) (i) Name the various types of plasticizers used in concrete and discuss the action in detail. (10)
- (ii) List the materials used for air entrainment in concrete and describe their effects on the properties of concrete. (6)

OR

- (b) Discuss the effects of adding fly ash, silica fume and ground granulated blast furnace slag in concrete.
13. (a) What are the factors affecting proportioning of a concrete mix? Discuss each in detail.

OR

- (b) Design a concrete mix for reinforced concrete work for the following requirements using IS : 10262-2007 code.

Characteristic strength at 28 days : 35 MPa

Exposure condition : severe

Degree of workability : slump = 50 mm

Quality control : very good

Cement : OPC (specific gravity = 3.15)

Fine aggregate : zone II sand (specific gravity = 2.64)

Coarse aggregate : maximum size = 20mm (specific gravity = 2.7)

Water absorption of coarse aggregate = 1%

Free surface moisture in sand = 2%

Assume any data required.



14. (a) What is meant by Workability of Concrete ? Enumerate the various methods to ascertain the workability. Discuss any one of them in brief.

OR

- (b) Explain the method of finding the flexural and split tensile strength for concrete.
15. (a) Brief the production of geo-polymer concrete and enlist the salient parameters affecting the compressive strength of geo-polymer concrete.

OR

- (b) Write short notes on :

- | | |
|----------------------------|-----|
| (i) Shortcrete | (4) |
| (ii) SIFCON | (4) |
| (iii) Ready mixed concrete | (4) |
| (iv) Ferrocement | (4) |

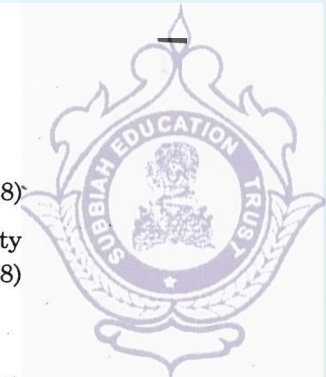

PART B — (5 × 16 = 80 marks)

11. (a) (i) Explain the effect of properties of aggregate on concrete. (8)
 (ii) What is the effect of water cement ratio on strength and durability of concrete? (8)

Or

- (b) (i) Explain physical properties of OPC. (8)
 (ii) Compare the physical properties of 33, 43 and 53 grades of concrete. (8)

12. (a) Differentiate between accelerators and retarders with suitable examples and also how you can determine dosage of admixtures? (16)

Or

- (b) Explain the effect of concrete properties while adding silica fume and GGBS. (16)

13. (a) Design a concrete mix for M₄₅, grade of concrete using IS method with the following data :

- (i) Type of cement – OPC 43 grades
- (ii) Maximum size of aggregate – 20 mm
- (iii) Exposure condition – Severe (RCC)
- (iv) Workability – 125 mm slump
- (v) Minimum cement content – 320 kg/m³
- (vi) Maximum W/C – 0.45
- (vii) Method of placing concrete – pumping
- (viii) Degree of supervision – good
- (ix) Type of aggregate – Crushed angular aggregate
- (x) Super plasticizer will be used
- (xi) Specific gravity of coarse aggregate – 2.80
- (xii) Specific gravity of fine aggregate – 2.70
- (xiii) Water absorption : Coarse aggre. – 0.5%, fine aggre. – 1%.

Grading of coarse aggregate is conforming to Table 2 of IS 383 and grading of Fine Grading of coarse aggregate is conforming to Table 2 of IS 383 and grading of fine aggregate is falling in zone II.

Or



- (b) Design a concrete mix for M35 grade of concrete using F type fly ash. Adopt BIS method with the following data :
- (i) Type of cement – OPC 43 grades
 - (ii) Maximum size of aggregate – 20 mm
 - (iii) Exposure condition – Severe (RCC)
 - (iv) Workability – 100 mm slump
 - (v) Minimum cement content – 320 kg/m³
 - (vi) Maximum W/C – 0.45
 - (vii) Method of placing concrete – pumping
 - (viii) Degree of supervision – good
 - (ix) Type of aggregate – Crushed angular aggregate
 - (x) Super plasticizer will be used
 - (xi) Specific gravity of coarse aggregate – 2.80
 - (xii) Specific gravity of fine aggregate – 2.70
 - (xiii) Specific gravity of fly ash – 2.2
 - (xiv) Water absorption : Coarse aggre. – 0.5%, fine aggre. – Nil.
- Grading of coarse aggregate is conforming to Table 2 of IS 383 and grading of Fine aggregate is falling in zone I.

14. (a) Explain the procedure of any three tests conducted on workability of concrete. (16)

Or

- (b) Explain the factors influencing the strength results. (16)

15. (a) Explain the following : (6 + 5 + 5)
- (i) High strength concrete
 - (ii) Fibre reinforced concrete
 - (iii) Ready mix concrete.

Or

- (b) Explain the following : (5 + 6 + 5)
- (i) Ferrocement concrete
 - (ii) High performance concrete
 - (iii) Geopolymer concrete.